



STAUFF MCS Multi Couplings

Quick-connect systems for
multiple hydraulic lines

Product Catalogue

Version
06/2026

Germany

Walter Stauffenberg GmbH & Co. KG

Im Ehrenfeld 4
58791 Werdohl

www.stauff.com

STAUFF products and services are globally available through wholly-owned subsidiaries and a tight network of authorised distributors and representatives in all major industrial regions of the world.

You can find detailed contact information on the last two pages of this product catalogue or at www.stauff.com/contact.

Please note: Unless otherwise stated, all data and figures in this product catalogue are approximate values and are only valid as references, which are not binding (also in respect to any third parties' rights of protection) and thus do not release the customer / user from checking and testing the suitability of the products for the foreseen purposes. Therefore, data and figures can only be used in a limited sense for construction purposes.

The application of the products is beyond the control possibilities of the manufacturer and, therefore, is exclusively subject to the responsibility of the customer / user.

In the event that a liability is nevertheless considered, any compensation will be limited to the value of the goods supplied by the manufacturer and used by the customer / user. As a matter of course, the manufacturer guarantees the perfect quality of all products in accordance with the General Terms and Conditions of Business and Sale.

Subject to modifications due to the ongoing development and improvement of the products.

With the publication of this product catalogue, previous editions are no longer valid.



Multi Couplings	Series QRC-2D ▪ 2-Lines	4	2D
	Series QRC-4D ▪ 4-Lines	8	4D
	Series QRC-5D ▪ 5-Lines	12	5D
	Series QRC-6D ▪ 6-Lines	16	6D
	Series QRC-4DV ▪ 4-Lines ▪ Mounted on Front Loader Hydraulic Valves	20	4DV
	Series QRC-6DE ▪ 5-Lines ▪ with a Port for an Electric Socket	24	6DE



Series QRC-2D • 2-Lines Multi Coupling

2D

Material	Carbon Steel, Polyamide and Aluminum
Surface Finishing	Zinc-Nickel and Aluminum Components in Black Anodized
Standard Seal Material(s)	NBR (Buna-N®), Polyurethane, PTFE ²
Working Temperature	-25° C ... +100° C / -13° F ... +212° F
Connection	pressing the red button to allow the movement of the handle, followed by the alignment of the guide pins of the mobile half in the guide holes of the fixed manifold, allowing the joining of both parts
Disconnection	press the red button to allow the handler retraction
Connect Under Pressure	allowed
Application	Agricultural and Forestry Machinery, Construction Machinery, Road Machines

² Alternative seal materials are available on request.

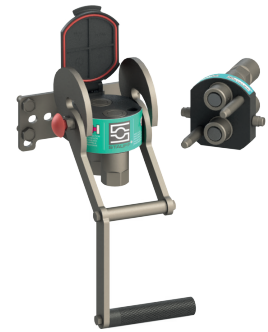

Technical Data

Series	Lines	DN Zoll Inch	DN metric ISO 4397	Q _{max}		Working Pressure Connected		Spillage	
				l/min	US GPM	bar	PSI	ml	fl oz
QRC-2D2	2	3/8"	10	50	13.21	350	5076	0,016	.0005
QRC-2D3	2	1/2"	12,5	90	20.87	280	4061	0,020	.0007
QRC-2D5	2	3/4"	19	200	33.02	250	3626	0,036	.0012
QRC-2D6	2	1"	25	300	52.83	250	3626	0,060	.0020

Flow Characteristics

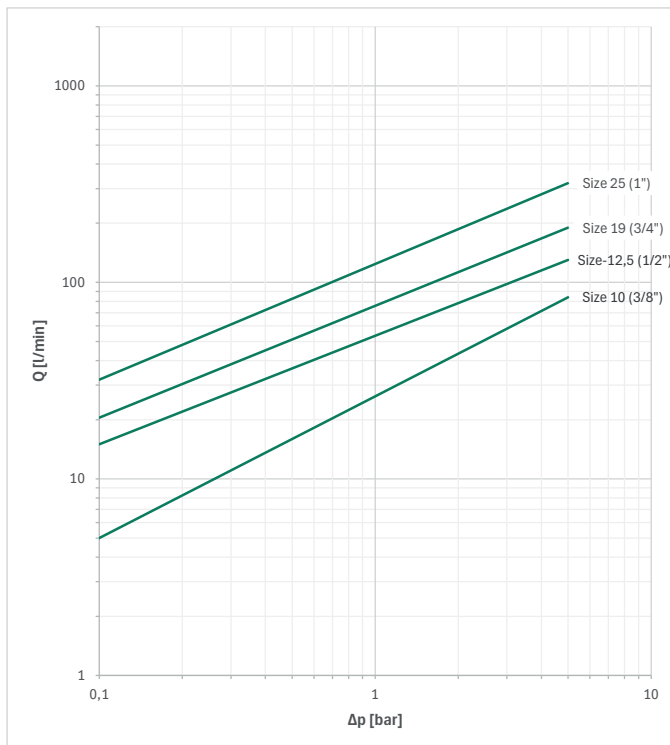

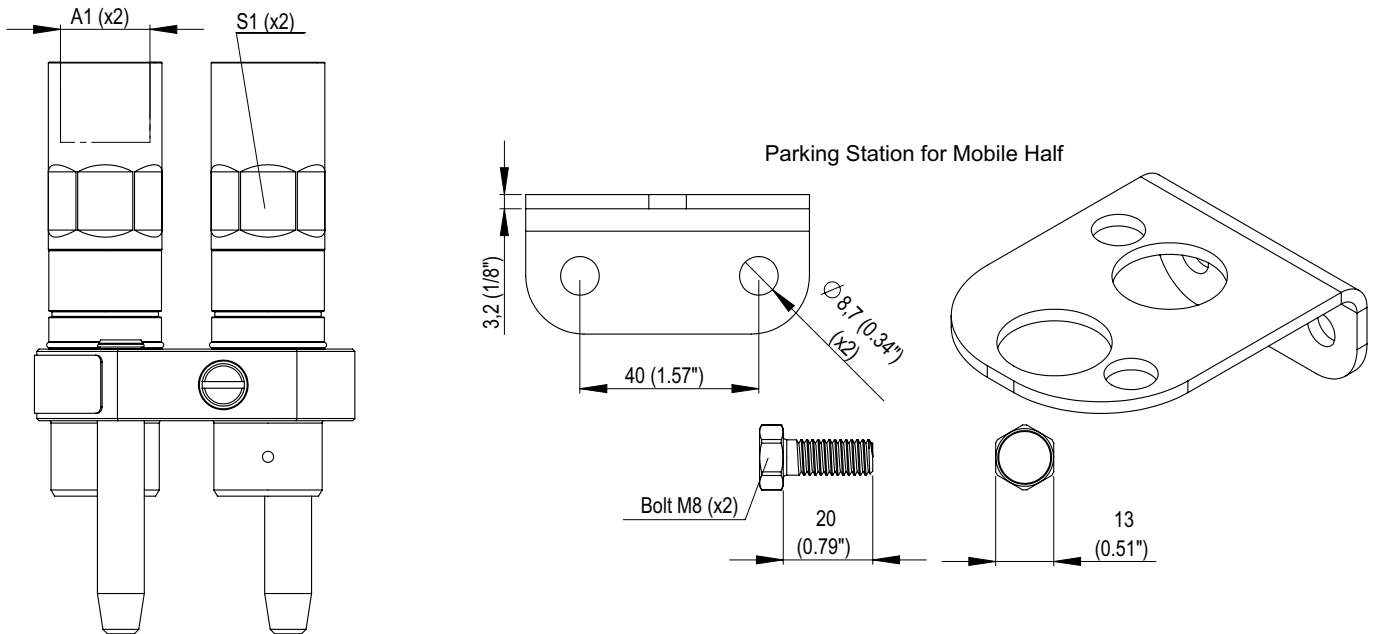
Series QRC-2D • 2-Lines Multi Coupling • Mobile Half
2D

Size mm (in)	Number of Couplers	A1 Thread	Standard Thread	Torque Nm	S1 mm (in)	Mobile Half Ordering Codes	Weight (#/lbs)
2L: 10 (3/8")	2/2	13/16" UN ORFS (ext.) 2x	SAE J1453	42 - 52	19,1 (3/4")	QRC-2D2-M-03-S1-W264AU-ST	731 (1.61)
	2/2	M18x1,50 L12 (ext.) 2x	ISO 8434-1-L	46 - 60	19,1 (3/4")	QRC-2D2-M-L2-S1-W264AU-ST	706 (1.56)
	2/2	M22x1,50 L15 (ext.) 2x	ISO 8434-1-L	74 - 96	19,1 (3/4")	QRC-2D2-M-L3-S1-W264AU-ST	711 (1.57)
	2/2	3/8" BSP (int.) 2x	DIN 3852-2	40 - 56	19,1 (3/4")	QRC-2D2-M-G2-S1-W264AU-ST	614 (1.32)
	2/2	1/2" BSP (int.) 2x	DIN 3852-2	72 - 88	19,1 (3/4")	QRC-2D2-M-G3-S1-W264AU-ST	719 (1.59)
2L: 12,5 (1/2")	2/2	9/16" UNF ORB (int.) 2x	SAE J1926	26 - 34	19,1 (3/4")	QRC-2D2-M-U2-S1-W264AU-ST	730 (1.61)
	2/2	1/2" BSP (int.) 2x	DIN 3852-2	72 - 88	22,2 (7/8")	QRC-2D3-M-G3-S1-W264AU-ST	633 (1.40)
	2/2	1/2" NPTF (int.) 2x	ANSI B1.20.3	52 - 66	22,2 (7/8")	QRC-2D3-M-N3-S1-W264AU-ST	638 (1.41)
	2/2	3/4" UNF ORB (int.) 2x	SAE J1926	48 - 62	22,2 (7/8")	QRC-2D3-M-U3-S1-W264AU-ST	635 (1.40)
	2/2	M22x1,50 L15 (ext.) 2x	ISO 8434-1-L	74 - 96	22,2 (7/8")	QRC-2D3-M-L3-S1-W264AU-ST	747 (1.65)
2L: 19 (3/4")	2/2	M24x1,50 S16 (ext.) 2x	ISO 8434-1-S	82 - 108	22,2 (7/8")	QRC-2D3-M-S3-S1-W264AU-ST	659 (1.44)
	2/2	3/4" BSP (int.) 2x	DIN 3852-2	120 - 150	28,6 (1.1/8")	QRC-2D5-M-G5-S1-W264AU-ST	1.265 (2.79)
2L: 25 (1")	2/2	1.1/16" UN ORB (int.) 2x	SAE J1926	90 - 116	28,6 (1.1/8")	QRC-2D5-M-U5-S1-W264AU-ST	1.261 (2.78)
	2/2	1" BSP (int.) 2x	DIN 3852-2	200 - 240	36,5 (1.7/16")	QRC-2D6-M-G6-S1-W264AU-ST	2.399 (5.29)
	2/2	1.5/16" UN ORB (int.) 2x	SAE J1926	128 - 160	36,5 (1.7/16")	QRC-2D6-M-U6-S1-W264AU-ST	2.379 (5.25)

To order a product with Parking Station, you should replace the „M“ behind the second hyphen with „MH“.
Ex.: QRC-2D2-MH-03-S1-W264AU-ST

Series QRC-2D • 2-Lines Multi Coupling • Parking Station for Mobile Half

Size mm (in)	Ordering Codes
2L: 10 (3/8")	QRC-2D2-HM-W3AU-ST
2L: 12,5 (1/2")	QRC-2D3-HM-W3AU-ST
2L: 19 (3/4")	QRC-2D5-HM-W3AU-ST
2L: 25 (1")	QRC-2D6-HM-W3AU-ST



Series QRC-2D • 2-Lines Multi Coupling • Fixed Half

2D

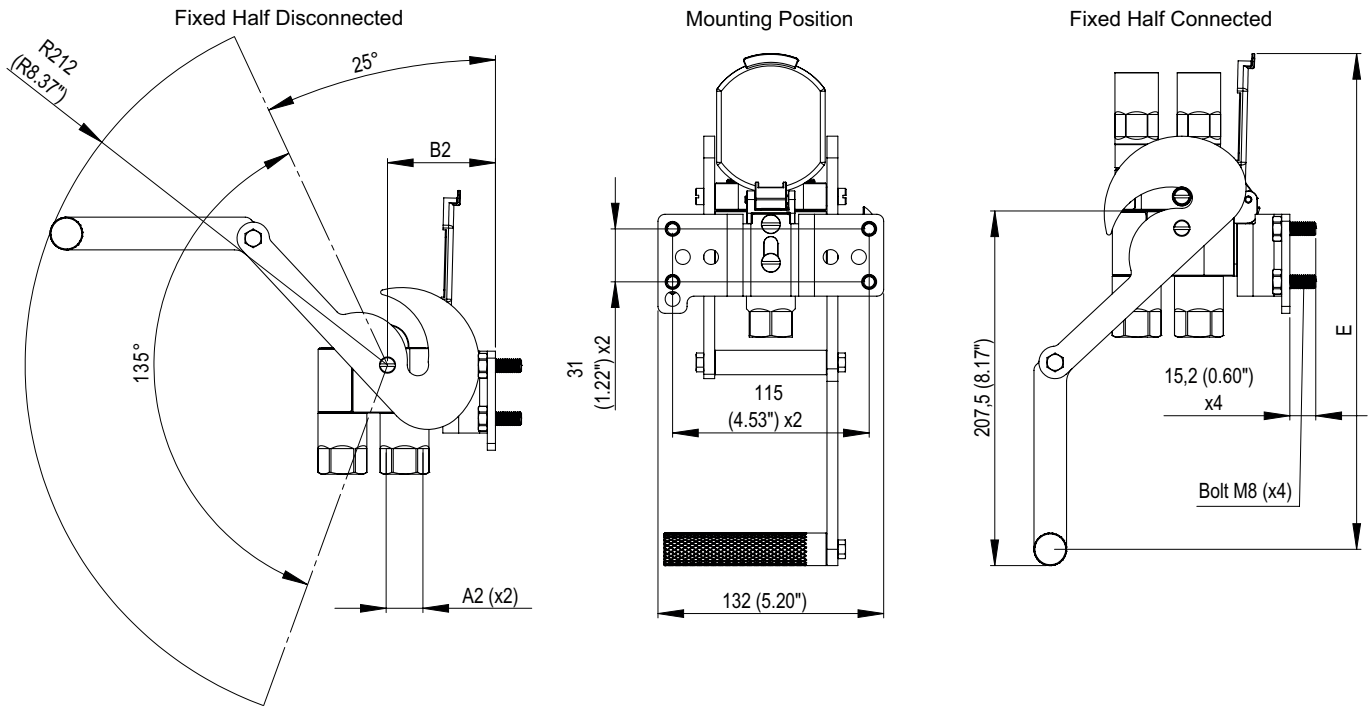

Size mm (in)	Number of Couplers	A2 Thread	Standard Thread	Torque Nm	B2 mm (in)	E mm (in)	Fixed Half Ordering Codes	Weight (^g / _{lbs})
2L: 10 (3/8")	2/2	13/16" UN ORFS (ext.) 2x	SAE J1453	42 - 52	59,5 (2.34")	291,7 (11.48")	QRC-2D2-F-03-S1-W264AU-ST	1.695 (3.74)
	2/2	M18x1,50 L12 (ext.) 2x	ISO 8434-1-L	46 - 60	59,5 (2.34")	291,7 (11.48")	QRC-2D2-F-L2-S1-W264AU-ST	1.691 (3.73)
	2/2	M22x1,50 L15 (ext.) 2x	ISO 8434-1-L	74 - 96	59,5 (2.34")	291,7 (11.48")	QRC-2D2-F-L3-S1-W264AU-ST	1.696 (3.74)
	2/2	3/8" BSP (int.) 2x	DIN 3852-2	40 - 56	59,5 (2.34")	291,7 (11.48")	QRC-2D2-F-G2-S1-W264AU-ST	1.583 (3.49)
	2/2	1/2" BSP (int.) 2x	DIN 3852-2	72 - 88	59,5 (2.34")	291,7 (11.48")	QRC-2D2-F-G3-S1-W264AU-ST	1.605 (3.54)
2L: 12,5 (1/2")	2/2	9/16" UNF ORB (int.) 2x	SAE J1926	26 - 34	59,5 (2.34")	291,7 (11.48")	QRC-2D2-F-U2-S1-W264AU-ST	1.683 (3.71)
	2/2	1/2" BSP (int.) 2x	DIN 3852-2	72 - 88	62,1 (2.34")	298,8 (11.76")	QRC-2D3-F-G3-S1-W264AU-ST	1.785 (3.94)
	2/2	1/2" NPT (int.) 2x	ANSI B1.20.1	52 - 66	62,1 (2.34")	298,8 (11.76")	QRC-2D3-F-N3-S1-W264AU-ST	1.830 (4.03)
	2/2	3/4" UNF ORB (int.) 2x	SAE J1926	48 - 62	62,1 (2.34")	298,8 (11.76")	QRC-2D3-F-U3-S1-W264AU-ST	1.792 (3.95)
	2/2	M22x1,50 L15 (ext.) 2x	ISO 8434-1-L	74 - 96	62,1 (2.34")	298,8 (11.76")	QRC-2D3-F-L3-S1-W264AU-ST	1.897 (4.19)
2L: 19 (3/4")	2/2	M24x1,5 S16 (ext.) 2x	ISO 8434-1-S	82 - 108	62,1 (2.34")	298,8 (11.76")	QRC-2D3-F-S3-S1-W264AU-ST	1.910 (4.21)
	2/2	3/4" BSP (int.) 2x	DIN 3852-2	120 - 150	66,9 (2.63")	307,0 (12.08")	QRC-2D5-F-G5-S1-W264AU-ST	2.205 (4.86)
2L: 25 (1")	2/2	1.1/16" UN ORB (int.) 2x	SAE J1926	90 - 116	66,9 (2.63")	307,0 (12.08")	QRC-2D5-F-U5-S1-W264AU-ST	2.195 (4.84)
	2/2	1" BSP (int.) 2x	DIN 3852-2	200 - 240	77,9 (3.06")	329,6 (12.98")	QRC-2D6-F-G6-S1-W264AU-ST	3.678 (8.11)
	2/2	1.5/16" UN ORB (int.) 2x	SAE J1926	128 - 160	77,9 (3.06")	329,6 (12.98")	QRC-2D6-F-U6-S1-W264AU-ST	3.766 (8.09)



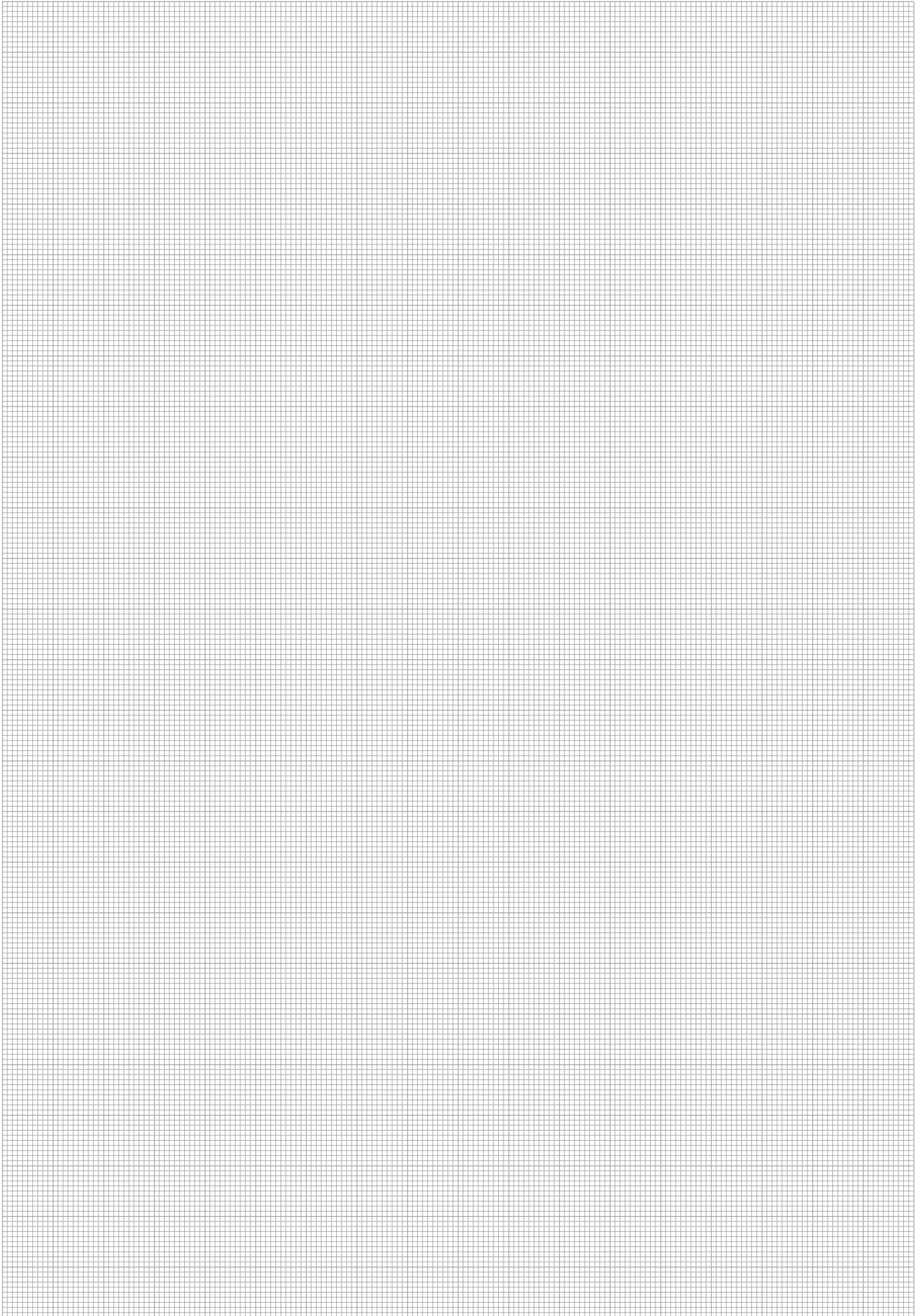

Series QRC-4D ▪ 4-Lines Multi Coupling

4D

Material	Carbon Steel, Polyamide and Aluminum
Surface Finishing	Zinc-Nickel and Aluminum Components in Black Anodized
Standard Seal Material(s)	NBR (Buna-N®), Polyurethane, PTFE ²
Working Temperature	-25° C ... +100° C / -13° F ... +212° F
Connection	pressing the red button to allow the movement of the handle, followed by the alignment of the guide pins of the mobile half in the guide holes of the fixed manifold, allowing the joining of both parts
Disconnection	press the red button to allow the handler retraction
Connect Under Pressure	allowed
Application	Agricultural and Forestry Machinery, Construction Machinery, Road Machines, Industrial Hydraulic, Oil and gas industry

² Alternative seal materials are available on request.

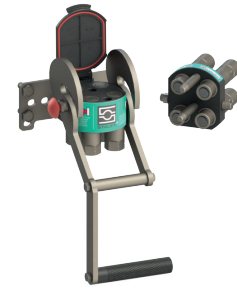

Technical Data

Series	Lines	DN Zoll Inch	DN metric ISO 4397	Q _{max}		Working Pressure Connected		Spillage	
				l/min	US GPM	bar	PSI	ml	fl oz
QRC-4D1	4	1/4"	6,3	24	6.34	300	4351	0,028	.0009
QRC-4D2	4	3/8"	10	50	13.21	280	4061	0,032	.0011
QRC-4D3	4	1/2"	12,5	90	20.87	250	3626	0,040	.0014
QRC-4D5	4	3/4"	19	200	33.02	250	3626	0,056	.0019

Flow Characteristics

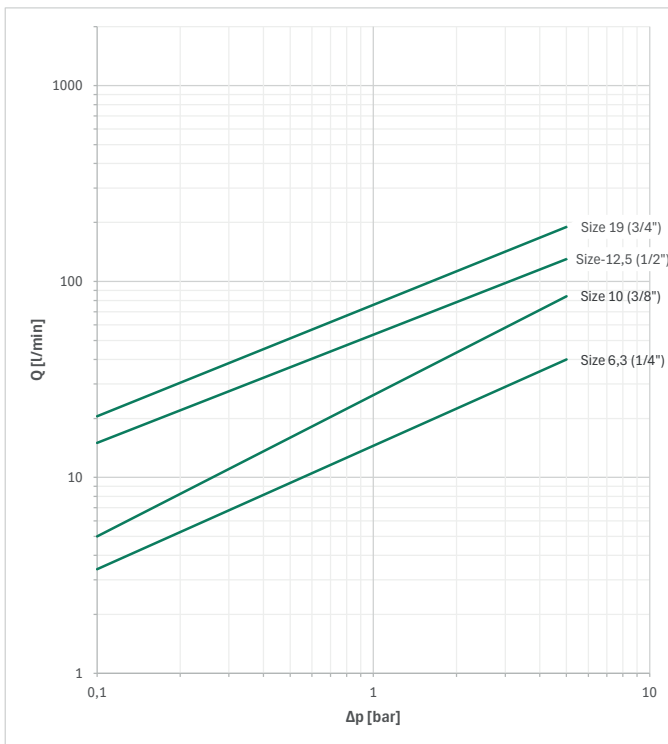

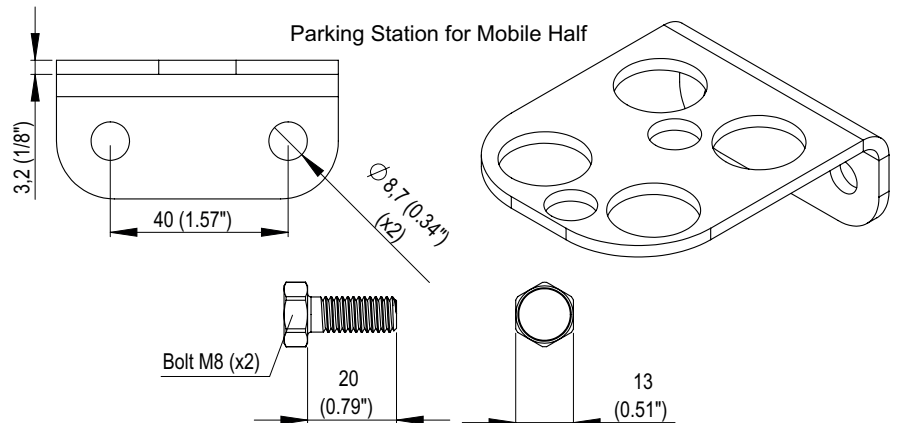
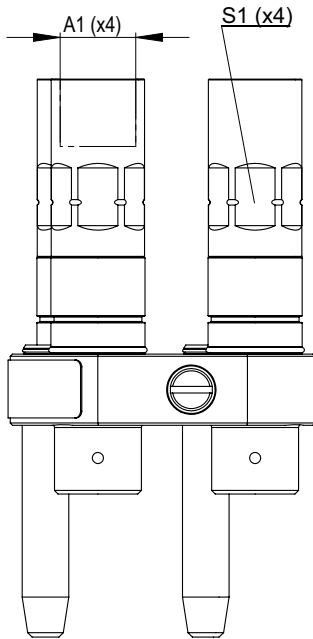
Series QRC-4D • 4-Lines Multi Coupling • Mobile Half
4D

Size mm (in)	Number of Couplers	A1 Thread	Standard Thread	Torque Nm	S1 mm (in)	Mobile Half Ordering Codes	Weight (lb/s)
4L: 6,3 (1/4")	4/4	7/16" UNF JIC (ext.) 4x	SAE J514	16 - 19	15,9 (5/8")	QRC-4D1-M-J1-S1-W264AU-ST	659 (1.45)
	4/4	M20x1,50 S12 (ext.) 4x	ISO 8434-1-S	68 - 86	15,9 (5/8")	QRC-4D1-M-S2-S1-W264AU-ST	699 (1.54)
	4/4	3/8" BSP (int.) 4x	DIN 3852-2	40 - 56	15,9 (5/8")	QRC-4D1-M-G2-S1-W264AU-ST	710 (1.57)
	4/4	9/16" UNF ORB (int.) 4x	SAE J1926	26 - 34	15,9 (5/8")	QRC-4D1-M-U2-S1-W264AU-ST	550 (1.21)
4L: 10 (3/8")	2/4	M22x1,50 IL15 (ext.) 2x	ISO 8434-1-L	74 - 96	19,1 (3/4")	QRC-4D2-M-S2-S1-W264AU-ST	670 (1.48)
	3/4	3/8" BSP (int.) 3x	DIN 3852-2	40 - 56	19,1 (3/4")	QRC-4D2-M-G2-S1-W264AU-ST000AB	670 (1.48)
	4/4	M18x1,50 L12 (ext.) 4x	ISO 8434-1-L	46 - 60	19,1 (3/4")	QRC-4D2-M-L2-S1-W264AU-ST	801 (1.77)
	4/4	M22x1,50 IL15 (ext.) 4x	ISO 8434-1-L	74 - 96	19,1 (3/4")	QRC-4D2-M-L3-S1-W264AU-ST	881 (1.94)
	4/4	M20x1,50 S12 (ext.) 4x	ISO 8434-1-S	68 - 86	19,1 (3/4")	QRC-4D2-M-S2-S1-W264AU-ST	949 (2.09)
	4/4	3/8" BSP (int.) 4x	DIN 3852-2	40 - 56	19,1 (3/4")	QRC-4D2-M-G2-S1-W264AU-ST	741 (1.63)
	4/4	1/2" BSP (int.) 4x	DIN 3852-2	72 - 88	25,4 (1")	QRC-4D2-M-G3-S1-W264AU-ST	946 (2.06)
	4/4	3/8" NPTF (int.) 4x	ANSI B1.20.3	30 - 40	19,1 (3/4")	QRC-4D2-M-N2-S1-W264AU-ST	750 (1.65)
	4/4	1/2" NPT (int.) 4x	ANSI B1.20.1	52 - 66	25,4 (1")	QRC-4D2-M-N3-S1-W264AU-ST	948 (2.09)
	4/4	9/16" UNF ORB (int.) 4x	SAE J1926	26 - 34	19,1 (3/4")	QRC-4D2-M-U2-S1-W264AU-ST	941 (2.07)
	4/4	3/4" UNF ORB (int.) 4x	SAE J1926	48 - 62	23,8 (13/16")	QRC-4D2-M-U3-S1-W264AU-ST	881 (1.94)
	4L: 12,5 (1/2")	3/4	3/4" UNF ORB (int.) 1x & 1.1/16" UN ORB (int.) 1x & 1.3/16" UN ORB (int.) 1x	SAE J1926	-	22,2 (7/8")	QRC-4D3-M-U3U5U5A-S1-W264AU-ST000AB
2/4		1/2" BSP (int.) 2x	DIN 3852-2	72 - 88	22,2 (7/8")	QRC-4D3-M-G3-S1-W264AU-ST000AA	1.059 (2.33)
3/4		3/4" UNF ORB (int.) 3x	SAE J1926	48 - 62	22,2 (7/8")	QRC-4D3-M-G5-S1-W264AU-ST000AB	1.375 (3.03)
4/4		1/2" BSP (int.) 2x & 3/4" BSP (int.) 2x	DIN 3852-2	-	-	QRC-4D3-M-G3G5-S1-W264AU-ST	1.600 (3.53)
4/4		3/4" UNF ORB (int.) 2x & 1.1/16" UN ORB (int.) 2x	SAE J1926	-	-	QRC-4D3-M-U3U5-S1-W264AU-ST	1.607 (3.54)
4/4		M22x1,50 L15 (ext.) 4x	ISO 8434-1-L	74 - 96	23,8 (15/16")	QRC-4D3-M-L3-S1-W264AU-ST	1.415 (3.12)
4/4		M24x1,50 S16 (ext.) 4x	ISO 8434-1-S	82 - 108	22,2 (7/8")	QRC-4D3-M-S3-S1-W264AU-ST	1.674 (3.69)
4/4		1/2" BSP (int.) 4x	DIN 3852-2	72 - 88	22,2 (7/8")	QRC-4D3-M-G3-S1-W264AU-ST	1.400 (3.09)
4/4		3/4" BSP (int.) 4x	DIN 3852-2	120 - 150	30,0 (1.3/16")	QRC-4D3-M-G5-S1-W264AU-ST	1.811 (3.99)
4/4		1/2" NPTF (int.) 4x	ANSI B1.20.3	52 - 66	22,2 (7/8")	QRC-4D3-M-N3-S1-W264AU-ST	1.415 (3.12)
4/4		3/4" UNF ORB (int.) 4x	SAE J1926	48 - 62	22,2 (7/8")	QRC-4D3-M-U3-S1-W264AU-ST	1.415 (3.12)
4/4		1.1/16" UN ORB (int.) 4x	SAE J1926	90 - 116	30,0 (1.3/16")	QRC-4D3-M-U5-S1-W264AU-ST	1.806 (3.98)
4L: 19 (3/4")	2/4	1.1/16" UN ORB (int.) 2x	SAE J1926	90 - 116	28,6 (1.1/8")	QRC-4D5-M-U5-S1-W264AU-ST000AA	2.380 (5.25)
	2/4	3/4" BSP (int.) 2x	DIN 3852-2	120 - 150	30,0 (1.3/16")	QRC-4D5-M-G5-S1-W264AU-ST000AA	2.199 (4.85)
	3/4	3/4" BSP (int.) 3x	DIN 3852-2	120 - 150	30,0 (1.3/16")	QRC-4D5-M-G5-S1-W264AU-ST000AB	2.553 (5.63)
	4/4	3/4" BSP (int.) 4x	DIN 3852-2	120 - 150	30,0 (1.3/16")	QRC-4D5-M-G5-S1-W264AU-ST	2.733 (6.03)
	4/4	1.1/16" UN ORB (int.) 3x	SAE J1926	90 - 116	28,6 (1.1/8")	QRC-4D5-M-U5-S1-W264AU-ST	2.734 (6.03)

To order a product with Parking Station, you should replace the „M“ behind the second hyphen with „MH“. Ex.: QRC-4D2-MH-L2-S1-W264AU-ST

Series QRC-4D • 4-Lines Multi Coupling • Parking Station for Mobile Half

Size mm (in)	Ordering Codes
4L: 6,3 (1/4")	QRC-4D1-HM-W3AU-ST
4L: 10 (3/8")	QRC-4D2-HM-W3AU-ST
4L: 12,5 (1/2")	QRC-4D3-HM-W3AU-ST
4L: 19 (3/4")	QRC-4D5-HM-W3AU-ST



Series QRC-4D • 4-Lines Multi Coupling • Fixed Half

4D

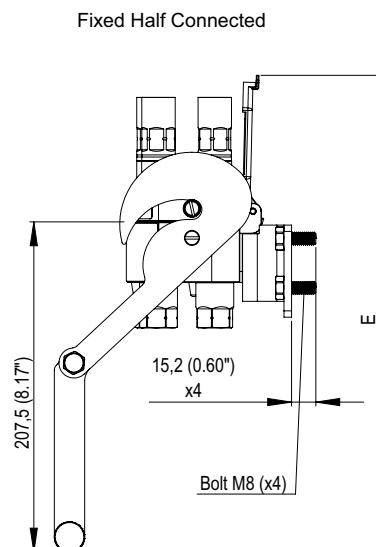
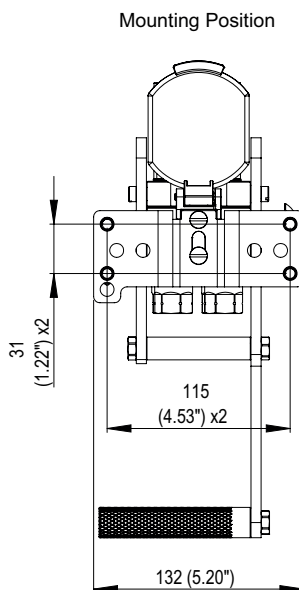
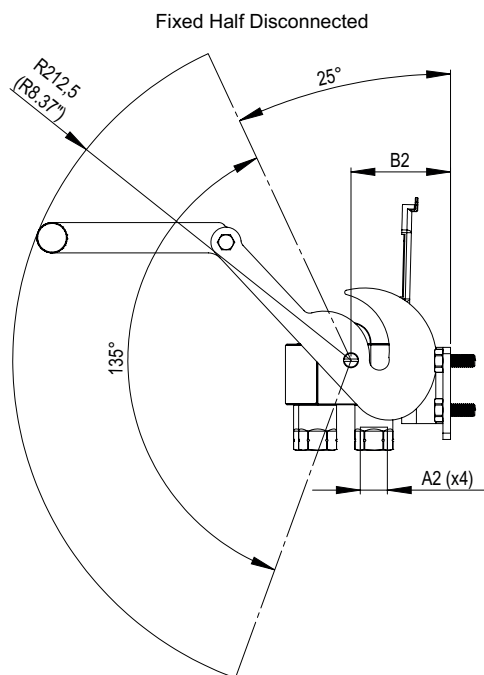

Size mm (in)	Number of Couplers	A2 Thread	Standard Thread	Torque Nm	B2 mm (in)	E mm (in)	Fixed Half Ordering Codes	Weight (lb/bs)
4L: 6,3 (1/4")	3/4	7/16" UNF JIC (ext.) 3x	SAE J514	15 - 18	59,5 (2.34")	291,7 (11.48")	QRC-4D1-F-J1-S1-W264AU-ST000AB	1.525 (3.36)
	4/4	7/16" UNF JIC (ext.) 4x	SAE J514	15 - 18	59,5 (2.34")	291,7 (11.48")	QRC-4D1-F-J1-S1-W264AU-ST	1.595 (3.52)
	4/4	M20x1,50 S12 (ext.) 4x	ISO 8434-1-S	68 - 86	59,5 (2.34")	291,7 (11.48")	QRC-4D1-F-S2-S1-W264AU-ST	1.645 (3.63)
	4/4	1/4" BSP (int.) 4x	DIN 3852-2	24 - 32	59,5 (2.34")	291,7 (11.48")	QRC-4D1-F-G1-S1-W264AU-ST	1.625 (3.58)
	4/4	3/8" BSP (int.) 4x	DIN 3852-2	40 - 56	59,5 (2.34")	291,7 (11.48")	QRC-4D1-F-G2-S1-W264AU-ST	1.510 (3.33)
	4/4	9/16" UNF ORB (int.) 4x	SAE J1926	26 - 34	59,5 (2.34")	291,7 (11.48")	QRC-4D1-F-U2-S1-W264AU-ST	1.470 (3.24)
4L: 10 (3/8")	2/4	M22x1,50 L15 (ext.) 2x	ISO 8434-1-L	74 - 96	62,1 (2.34")	298,8 (11.76")	QRC-4D2-F-L3-S1-W264AU-ST000AA	1.857 (4.09)
	3/4	3/8" BSP (int.) 3x	DIN 3852-2	40 - 56	62,1 (2.34")	298,8 (11.76")	QRC-4D2-F-G2-S1-W264AU-ST000AB	1.970 (4.34)
	4/4	11/16" UN ORFS (ext.) 4x	SAE J1453	32 - 38	62,1 (2.34")	298,8 (11.76")	QRC-4D2-F-O2-S1-W264AU-ST	2.230 (4.92)
	4/4	M18x1,50 L12 (ext.) 4x	ISO 8434-1-L	46 - 60	62,1 (2.34")	298,8 (11.76")	QRC-4D2-F-L2-S1-W264AU-ST	2.230 (4.92)
	4/4	M22x1,50 L15 (ext.) 4x	ISO 8434-1-L	74 - 96	62,1 (2.34")	298,8 (11.76")	QRC-4D2-F-L3-S1-W264AU-ST	2.257 (4.98)
	4/4	M20x1,50 S12 (ext.) 4x	ISO 8434-1-S	68 - 86	62,1 (2.34")	298,8 (11.76")	QRC-4D2-F-S2-S1-W264AU-ST	2.240 (4.94)
	4/4	3/8" BSP (int.) 4x	DIN 3852-2	40 - 56	62,1 (2.34")	298,8 (11.76")	QRC-4D2-F-G2-S1-W264AU-ST	2.030 (4.48)
	4/4	1/2" BSP (int.) 4x	DIN 3852-2	72 - 88	62,1 (2.34")	298,8 (11.76")	QRC-4D2-F-G3-S1-W264AU-ST	2.070 (4.56)
	4/4	3/8" NPT (int.) 4x	ANSI B1.20.1	30 - 40	62,1 (2.34")	298,8 (11.76")	QRC-4D2-F-N2-S1-W264AU-ST	2.025 (4.46)
	4/4	9/16" UNF ORB (int.) 4x	SAE J1926	26 - 34	62,1 (2.34")	298,8 (11.76")	QRC-4D2-F-U2-S1-W264AU-ST	2.230 (4.92)
4/4	3/4" UNF ORB (int.) 4x	SAE J1926	48 - 62	62,1 (2.34")	298,8 (11.76")	QRC-4D2-F-U3-S1-W264AU-ST	2030 (4.48)	
4L: 12,5 (1/2")	2/4	1/2" BSP (int.) 2x	DIN 3852-2	72 - 88	71,7 (2.82")	316,6 (12.46")	QRC-4D3-F-G3-S1-W264AU-ST000AA	2.280 (5.03)
	3/4	3/4" UNF ORB (int.) 1x & 1.1/16" UN ORB (int.) 1x & 1.3/16" UN ORB (int.) 1x	SAE J1926	-	71,7 (2.82")	316,6 (12.46")	QRC-4D3-F-U3U5U5A-S1-W264AU-ST000AB	2.499 (5.51)
	3/4	3/4" UNF ORB (int.) 3x	SAE J1926	48 - 62	71,7 (2.82")	316,6 (12.46")	QRC-4D3-F-G5-S1-W264AU-ST000AB	2.355 (5.19)
	4/4	1/2" BSP (int.) 2x & 3/4" BSP (int.) 2x	DIN 3852-2	-	71,7 (2.82")	316,6 (12.46")	QRC-4D3-F-G3G5-S1-W264AU-ST	2.566 (5.66)
	4/4	3/4" UNF ORB (int.) 2x & 1.1/16" UN ORB (int.) 2x	SAE J1926	-	71,7 (2.82")	316,6 (12.46")	QRC-4D3-F-U3U5-S1-W264AU-ST	2.526 (5.57)
	4/4	M22x1,50 L15 (ext.) 4x	ISO 8434-1-L	74 - 96	71,7 (2.82")	316,6 (12.46")	QRC-4D3-F-L3-S1-W264AU-ST	2.725 (6.01)
	4/4	M24x1,50 S16 (ext.) 4x	ISO 8434-1-S	82 - 108	71,7 (2.82")	316,6 (12.46")	QRC-4D3-F-S3-S1-W264AU-ST	2.740 (6.04)
	4/4	1/2" BSP (int.) 4x	DIN 3852-2	72 - 88	71,7 (2.82")	316,6 (12.46")	QRC-4D3-F-G3-S1-W264AU-ST	2.453 (5.41)
	4/4	3/4" BSP (int.) 4x	DIN 3852-2	120 - 150	71,7 (2.82")	316,6 (12.46")	QRC-4D3-F-G5-S1-W264AU-ST	2.580 (5.69)
	4/4	1/2" NPTF (int.) 4x	ANSI B1.20.3	52 - 66	71,7 (2.82")	316,6 (12.46")	QRC-4D3-F-N3-S1-W264AU-ST	2.544 (5.60)
	4/4	3/4" UNF ORB (int.) 4x	SAE J1926	48 - 62	71,7 (2.82")	316,6 (12.46")	QRC-4D3-F-U3-S1-W264AU-ST	2.470 (5.45)
	4/4	1.1/16" UN ORB (int.) 4x	SAE J1926	90 - 116	71,7 (2.82")	316,6 (12.46")	QRC-4D3-F-U5-S1-W264AU-ST	2.585 (5.70)
4L: 19 (3/4")	2/4	1.1/16" UN ORB (int.) 2x	SAE J1926	90 - 116	77,9 (3.06")	329,6 (12.98")	QRC-4D5-F-U5-S1-W264AU-ST000AA	3.284 (7.24)
	2/4	3/4" BSP (int.) 2x	DIN 3852-2	120 - 150	77,9 (3.06")	329,6 (12.98")	QRC-4D5-F-G5-S1-W264AU-ST000AA	3.239 (7.14)
	3/4	3/4" BSP (int.) 3x	DIN 3852-2	120 - 150	77,9 (3.06")	329,6 (12.98")	QRC-4D5-F-G5-S1-W264AU-ST000AB	3.414 (7.53)
	4/4	3/4" BSP (int.) 4x	DIN 3852-2	120 - 150	77,9 (3.06")	329,6 (12.98")	QRC-4D5-F-G5-S1-W264AU-ST	3.524 (7.80)
	4/4	1.1/16" UN ORB (int.) 4x	SAE J1926	90 - 116	77,9 (3.06")	329,6 (12.98")	QRC-4D5-F-U5-S1-W264AU-ST	3.509 (7.74)



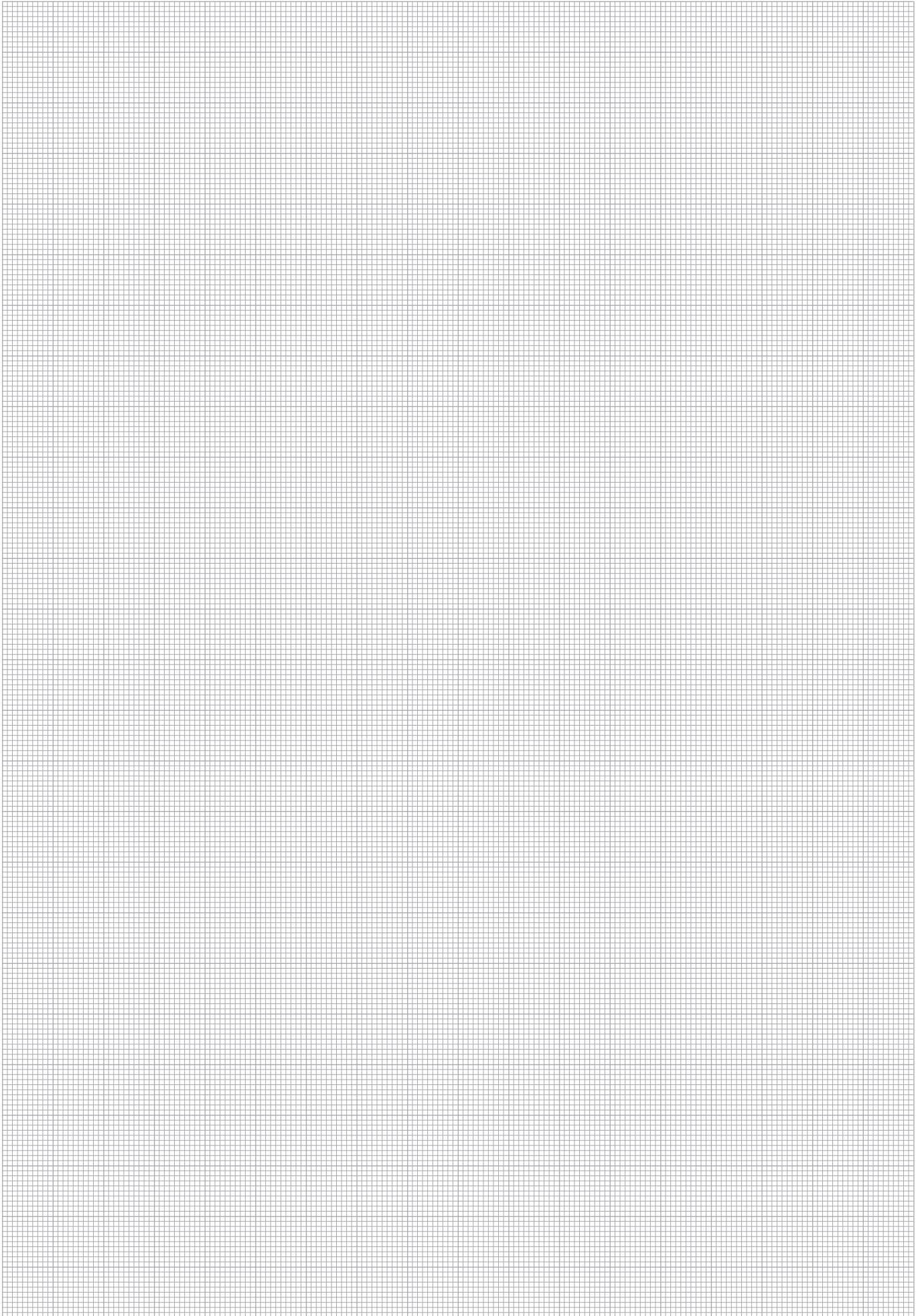

Series QRC-5D ▪ 5-Lines Multi Coupling

5D

Material	Carbon Steel, Polyamide and Aluminum
Surface Finishing	Zinc-Nickel and Aluminum Components in Black Anodized
Standard Seal Material(s)	NBR (Buna-N®), Polyurethane, PTFE ²
Working Temperature	-25° C ... +100° C / -13° F ... +212° F
Connection	pressing the red button to allow the movement of the handle, followed by the alignment of the guide pins of the mobile half in the guide holes of the fixed manifold, allowing the joining of both parts
Disconnection	press the red button to allow the handler retraction
Connect Under Pressure	allowed
Application	Agricultural and Forestry Machinery

² Alternative seal materials are available on request.



Technical Data

Series	Lines	DN Zoll Inch	DN metric ISO 4397	Q _{max}		Working Pressure Connected		Spillage	
				l/min	US GPM	bar	PSI	ml	fl oz
QRC-5D12	3/2	1/4" / 3/8"	6,3 / 10	24 / 50	6.34 / 13.21	300	4351	0,040	.0014
QRC-5D2	5	3/8"	10	50	13.21	300	4351	0,040	.0014
QRC-5D23	4/1	3/8" / 1/2"	10 / 12,5	50 / 90	13.21 / 20.87	250	3626	0,042	.0014
QRC-5D3	5	1/2"	12,5	90	20.87	250	3626	0,050	.0017

Flow Characteristics

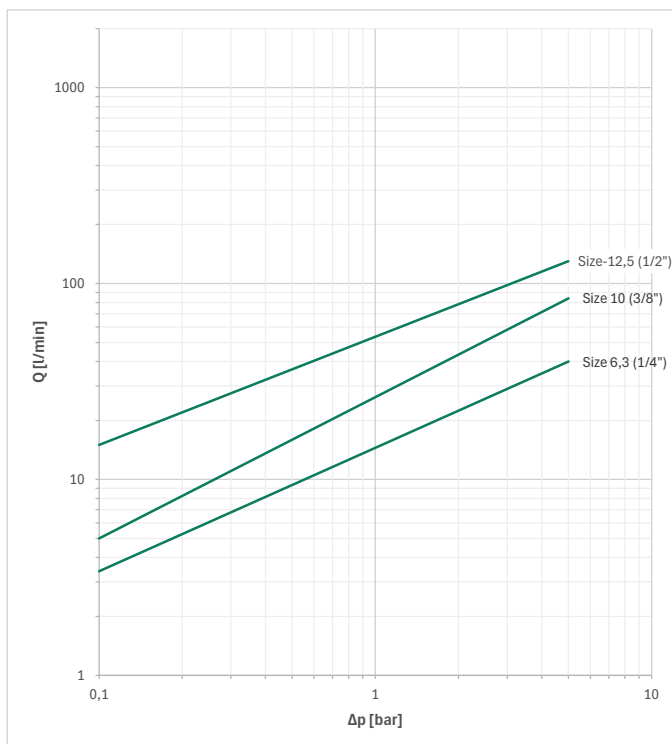

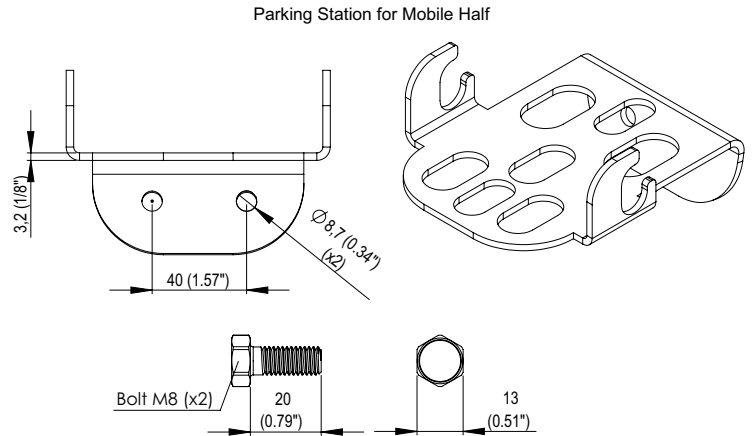
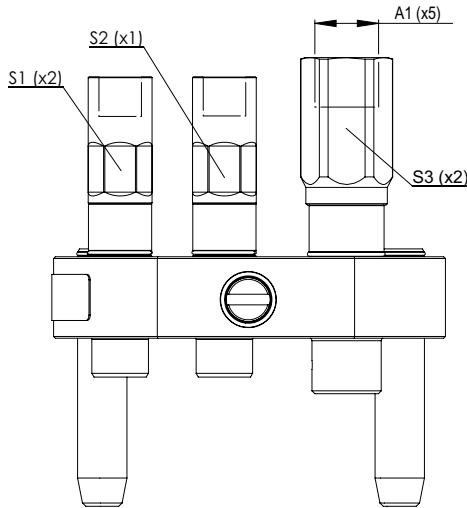
Series QRC-5D • 5-Lines Multi Coupling • Mobile Half

5D

Size mm (in)	Number of Couplers	A1 Thread	Standard Thread	Torque Nm	S1 mm (in)	S2 mm (in)	S3 mm (in)	Mobile Half	Weight (9/lbs)
3L: 6,3 (1/4") 2L: 10 (3/8")	5/5	9/16" UNF ORB (int.) 3x & 3/4" UNF ORB (int.) 2x	SAE J1926	-	15,9 (5/8")	15,9 (5/8")	23,8 (13/16")	QRC-5D12-M-U2U3-S1-W264AU-ST000BA*	2.179 (4.80)
	5/5	11/16" UN ORFS (ext.) 3x & 13/16" UN ORFS (ext.) 2x	SAE J1453	-	15,9 (5/8")	15,9 (5/8")	22,2 (7/8")	QRC-5D12-M-0203-S1-W264AU-ST000BA*	2.383 (5.25)
	5/5	M14x1,50 L8 (ext.) 3x & M24x1,50 S16 (ext.) 2x	ISO 8434-1	-	15,9 (5/8")	15,9 (5/8")	22,2 (7/8")	QRC-5D12-M-L1S3-S1-W264AU-ST000BA*	2.383 (5.25)
	3/5	M14x1,50 L8 (ext.) 3x	ISO 8434-1	-	15,9 (5/8")	15,9 (5/8")	-	QRC-5D12-M-L1-S1-W264AU-ST000AC	1.889 (4.16)
	4/5	M14x1,50 L8 (ext.) 2x & M24x1,50 S16 (ext.) 2x	ISO 8434-1	-	15,9 (5/8")	-	23,8 (13/16")	QRC-5D12-M-L1S3-S1-W264AU-ST000AD	1.919 (4.23)
	5/5	11/16" UN ORFS (ext.) 3x & 13/16" UN ORFS (ext.) 2x	SAE J1453	-	15,9 (5/8")	15,9 (5/8")	22,2 (7/8")	QRC-5D12-M-0203-S1-W264AU-ST	2.403 (5.30)
	5/5	M14x1,50 L8 (ext.) 3x & M24x1,50 S16 (ext.) 2x	ISO 8434-1	-	15,9 (5/8")	15,9 (5/8")	22,2 (7/8")	QRC-5D12-M-L1S3-S1-W264AU-ST	2.403 (5.30)
5L: 10 (3/8")	5/5	9/16" UNF ORB (int.) 3x & 3/4" UNF ORB (int.) 2x	SAE J1926	-	15,9 (5/8")	15,9 (5/8")	23,8 (13/16")	QRC-5D12-M-U2U3-S1-W264AU-ST	2.199 (4.85)
	5/5	11/16" UN ORFS (ext.) 3x & 13/16" UN ORFS (ext.) 2x	SAE J1453	-	22,2 (7/8")	22,2 (7/8")	23,8 (13/16")	QRC-5D2-M-U2U3-S1-W264AU-ST000BA*	1.299 (2.86)
	5/5	M14x1,50 L8 (ext.) 3x & M24x1,50 S16 (ext.) 2x	ISO 8434-1	-	22,2 (7/8")	22,2 (7/8")	22,2 (7/8")	QRC-5D2-M-L1S3-S1-W264AU-ST000BA*	1.503 (3.31)
	5/5	11/16" UN ORFS (ext.) 3x & 13/16" UN ORFS (ext.) 2x	SAE J1453	-	22,2 (7/8")	22,2 (7/8")	22,2 (7/8")	QRC-5D2-M-0203-S1-W264AU-ST000BA*	1.503 (3.31)
	3/5	M14x1,50 L8 (ext.) 3x	ISO 8434-1	-	22,2 (7/8")	22,2 (7/8")	-	QRC-5D2-M-S3-S1-W264AU-ST000AH	1.009 (2.22)
	4/5	M14x1,50 L8 (ext.) 2x & M24x1,50 S16 (ext.) 2x	ISO 8434-1	-	22,2 (7/8")	-	23,8 (13/16")	QRC-5D2-M-L1S3-S1-W264AU-ST000HI	1.029 (2.27)
	5/5	11/16" UN ORFS (ext.) 3x & 13/16" UN ORFS (ext.) 2x	SAE J1453	-	22,2 (7/8")	22,2 (7/8")	22,2 (7/8")	QRC-5D2-M-0203-S1-W264AU-ST	1.523 (3.36)
4L: 10 (3/8") 1L: 12,5 (1/2")	5/5	M14x1,50 L8 (ext.) 3x & M24x1,50 S16 (ext.) 2x	ISO 8434-1	-	22,2 (7/8")	22,2 (7/8")	22,2 (7/8")	QRC-5D2-M-L1S3-S1-W264AU-ST	1.523 (3.36)
	5/5	9/16" UNF ORB (int.) 3x & 3/4" UNF ORB (int.) 2x	SAE J1926	-	22,2 (7/8")	22,2 (7/8")	23,8 (13/16")	QRC-5D2-M-U2U3-S1-W264AU-ST	1.319 (2.91)
	5/5	M22x1,50 L15 (ext.) 5x	ISO 8434-1-L	74 - 96	19,1 (3/4")	19,1 (3/4")	19,1 (3/4")	QRC-5D23-M-L3-S1-W264AU-ST	1.646 (3.63)
	5/5	3/8" BSP (int.) 4x & 1/2" BSP (int.) 1x	DIN 3852-2	-	19,1 (3/4")	19,1 (3/4")	25,4 (1")	QRC-5D23-M-G2G3-S1-W264AU-ST	1.406 (2.29)
	5L: 12,5 (1/2")	5/5	1/2" BSP (int.) 5x	DIN 3852-2	72 - 88	22,2 (7/8")	22,2 (7/8")	22,2 (7/8")	QRC-5D3-M-G3-S1-W264AU-ST
5/5		3/4" BSP (int.) 5x	DIN 3852-2	120 - 150	30,0 (1.3/16")	30,0 (1.3/16")	30,0 (1.3/16")	QRC-5D3-M-G5-S1-W264AU-ST	2.661 (5.87)
5/5		1/2" NPTF (int.) 5x	ANSI B1.20.3	52 - 66	22,2 (7/8")	22,2 (7/8")	22,2 (7/8")	QRC-5D3-M-N3-S1-W264AU-ST	2.170 (4.78)
5/5		3/4" UNF ORB (int.) 5x	SAE J1926	48 - 62	22,2 (7/8")	22,2 (7/8")	22,2 (7/8")	QRC-5D3-M-U3-S1-W264AU-ST	2.176 (4.79)
5/5		1.1/16" UN ORB (int.) 5x	SAE J1926	90 - 116	30,0 (1.3/16")	30,0 (1.3/16")	30,0 (1.3/16")	QRC-5D3-M-U5-S1-W264AU-ST	2.656 (5.86)

*One of the lines does not connect under pressure.

To order a product with Parking Station, you should replace the „M“ behind the second hyphen with „MH“. Ex.: QRC-5D12-MH-0203-S1-W264AU-ST

Series QRC-5D • 5-Lines Multi Coupling • Parking Station for Mobile Half

Size mm (in)	Ordering Codes
5L: 10 (3/8")	QRC-5D2-HM-W3AU-ST
4L: 10 (3/8") & 1L: 12,5 (1/2")	QRC-5D23-HM-W3AU-ST
5L: 12,5 (1/2")	QRC-5D3-HM-W3AU-ST



Series QRC-5D • 5-Lines Multi Coupling • Fixed Half

5D

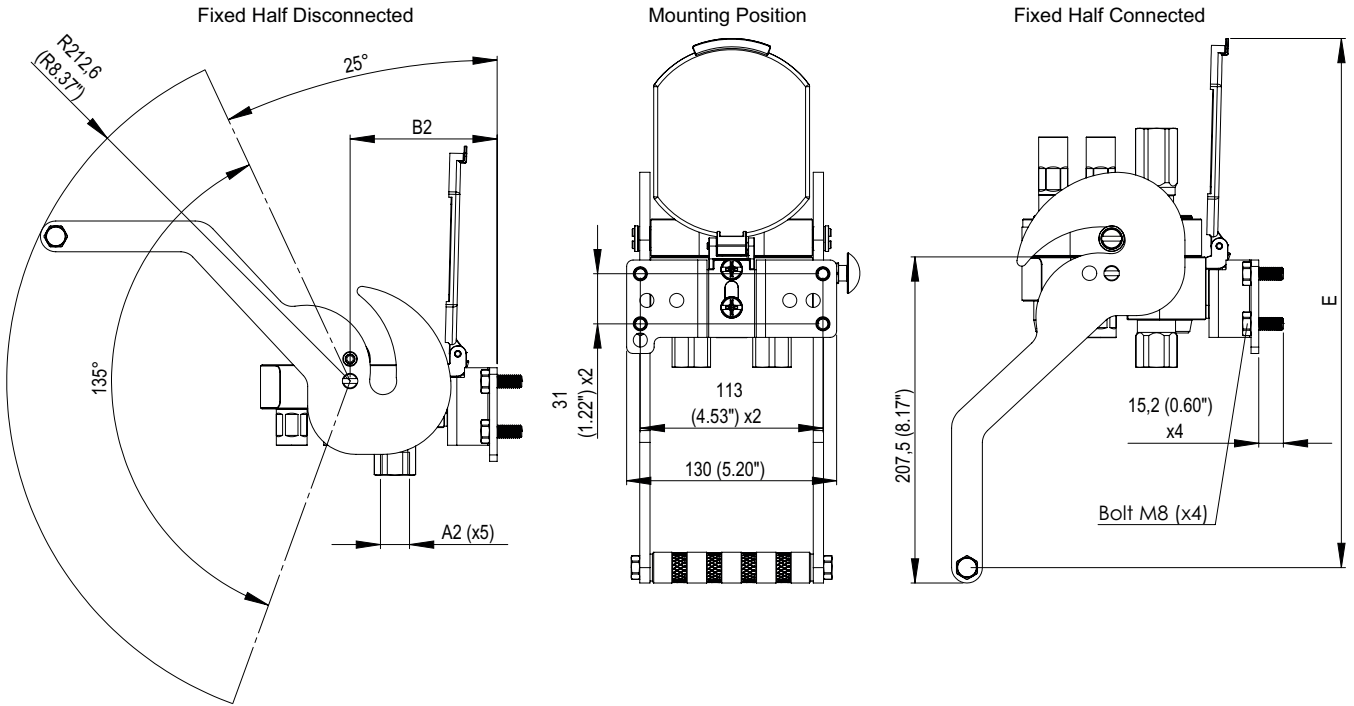

Size mm (in)	Number of Couplers	A2 Thread	Standard Thread	Torque Nm	B2 mm (in)	E mm (in)	Fixed Half Ordering Codes	Weight (9/lbs)
3L: 6,3 (1/4") 2L: 10 (3/8")	2/5	9/16" UNF ORB (int.) 2x	SAE J1926	26 - 34	90,9 (3.58")	337,1 (13.27")	QRC-5D12-F-U2-S1-W264AU-ST000AE	2.475 (5.46)
	2/5	M14x1,50 L8 (ext.) 2x	ISO 8434-1	20 - 28	90,9 (3.58")	337,1 (13.27")	QRC-5D12-F-L1-S1-W264AU-ST000AE	2.521 (5.56)
	2/5	3/8" BSP (int.) 2x	DIN 3852-2	40 - 56	90,9 (3.58")	337,1 (13.27")	QRC-5D12-F-G2-S1-W264AU-ST000AF	2.597 (5.73)
	2/5	1/2" BSP (int.) 2x	DIN 3852-2	72 - 88	90,9 (3.58")	337,1 (13.27")	QRC-5D12-F-G3-S1-W264AU-ST000AF	2.609 (5.75)
	2/5	3/4" UNF ORB (int.) 2x	SAE J1926	48 - 62	90,9 (3.58")	337,1 (13.27")	QRC-5D12-F-U3-S1-W264AU-ST000AF	2.599 (5.73)
	3/5	M14x1,50 L8 (ext.) 3x	ISO 8434-1	20 - 28	90,9 (3.58")	337,1 (13.27")	QRC-5D12-F-L1-S1-W264AU-ST000AC	2.662 (5.87)
	3/5	M14x1,50 L8 (ext.) 1x & M24x1,50 S16 (ext.) 2x	ISO 8434-1	-	90,9 (3.58")	337,1 (13.27")	QRC-5D12-F-L1S3-S1-W264AU-ST000AG	2.812 (6.20)
	4/5	M14x1,50 L8 (ext.) 2x & M24x1,50 S16 (ext.) 2x	ISO 8434-1	-	90,9 (3.58")	337,1 (13.27")	QRC-5D12-F-L1S3-S1-W264AU-ST000AD	2.923 (6.44)
	5/5	11/16"UN ORFS (ext.) 3x & 13/16"UN ORFS (ext.) 2x	SAE J1453	-	90,9 (3.58")	337,1 (13.27")	QRC-5D12-F-0203-S1-W264AU-ST	2.974 (6.16)
	5/5	M14x1,50 L8 (ext.) 3x & M24x1,50 S16 (ext.) 2x	ISO 8434-1	-	90,9 (3.58")	337,1 (13.27")	QRC-5D12-F-L1S3-S1-W264AU-ST	2.974 (6.16)
5/5	9/16" UNF ORB (int.) 3x & 3/4" UNF ORB (int.) 2x	SAE J1926	-	90,9 (3.58")	337,1 (13.27")	QRC-5D12-F-U2U3-S1-W264AU-ST	2.746 (6.05)	
5L: 10 (3/8")	2/5	M14x1,50 L8 (ext.) 2x	ISO 8434-1	20 - 28	66,9 (2.63")	307,0 (12.08")	QRC-5D2-F-L1-S1-W264AU-ST000AJ	2.135 (4.71)
	2/5	1/2" BSP (int.) 2x	DIN 3852-2	72 - 88	66,9 (2.63")	307,0 (12.08")	QRC-5D2-F-G3-S1-W264AU-ST000AJ	2.018 (4.45)
	2/5	3/4" UNF ORB (int.) 2x	SAE J1926	48 - 62	66,9 (2.63")	307,0 (12.08")	QRC-5D2-F-U3-S1-W264AU-ST000AJ	2.009 (4.43)
	3/5	M14x1,50 L8 (ext.) 3x	ISO 8434-1	20 - 28	66,9 (2.63")	307,0 (12.08")	QRC-5D2-F-L1-S1-W264AU-ST000AH	2.235 (4.93)
	3/5	M14x1,50 L8 (ext.) 1x & M24x1,50 S16 (ext.) 2x	ISO 8434-1	-	66,9 (2.63")	307,0 (12.08")	QRC-5D2-F-L1S3-S1-W264AU-ST000AH	2.135 (4.71)
	4/5	M14x1,50 L8 (ext.) 2x & M24x1,50 S16 (ext.) 2x	ISO 8434-1	-	66,9 (2.63")	307,0 (12.08")	QRC-5D2-F-L1S3-S1-W264AU-ST000AI	2.258 (4.98)
	5/5	11/16"UN ORFS (ext.) 3x & 13/16"UN ORFS (ext.) 2x	SAE J1453	-	66,9 (2.63")	307,0 (12.08")	QRC-5D2-F-0203-S1-W264AU-ST	2.258 (4.98)
	5/5	M14x1,50 L8 (ext.) 3x & M24x1,50 S16 (ext.) 2x	ISO 8434-1	-	66,9 (2.63")	307,0 (12.08")	QRC-5D2-F-L1S3-S1-W264AU-ST	2.258 (4.98)
4L: 10 (3/8") 1L: 12,5 (1/2")	5/5	M22x1,50 L15 (ext.) 5x	ISO 8434-1-L	-	71,7 (2.82")	316,6 (12.46")	QRC-5D23-F-L3-S1-W264AU-ST	2.711 (5.98)
	5/5	3/8" BSP (int.) 4x & 1/2" BSP (int.) 1x	DIN 3852-2	-	71,7 (2.82")	316,6 (12.46")	QRC-5D23-F-G2G3-S1-W264AU-ST	2.393 (5.28)
5L: 12,5 (1/2")	5/5	1/2" BSP (int.) 5x	DIN 3852-2	72 - 88	94,5 (3.72")	332,1 (13.08")	QRC-5D3-F-G3-S1-W264AU-ST	3.959 (8.57)
	5/5	3/4" BSP (int.) 5x	DIN 3852-2	120 - 150	94,5 (3.72")	332,1 (13.08")	QRC-5D3-F-G5-S1-W264AU-ST	4.038 (8.90)
	5/5	3/4" UNF ORB (int.) 5x	SAE J1926	48 - 62	94,5 (3.72")	332,1 (13.08")	QRC-5D3-F-U3-S1-W264AU-ST	3.889 (8.57)
	5/5	1.1/16" UN ORB (int.) 5x	SAE J1926	90 - 116	94,5 (3.72")	332,1 (13.08")	QRC-5D3-F-U5-S1-W264AU-ST	4.033 (8.89)



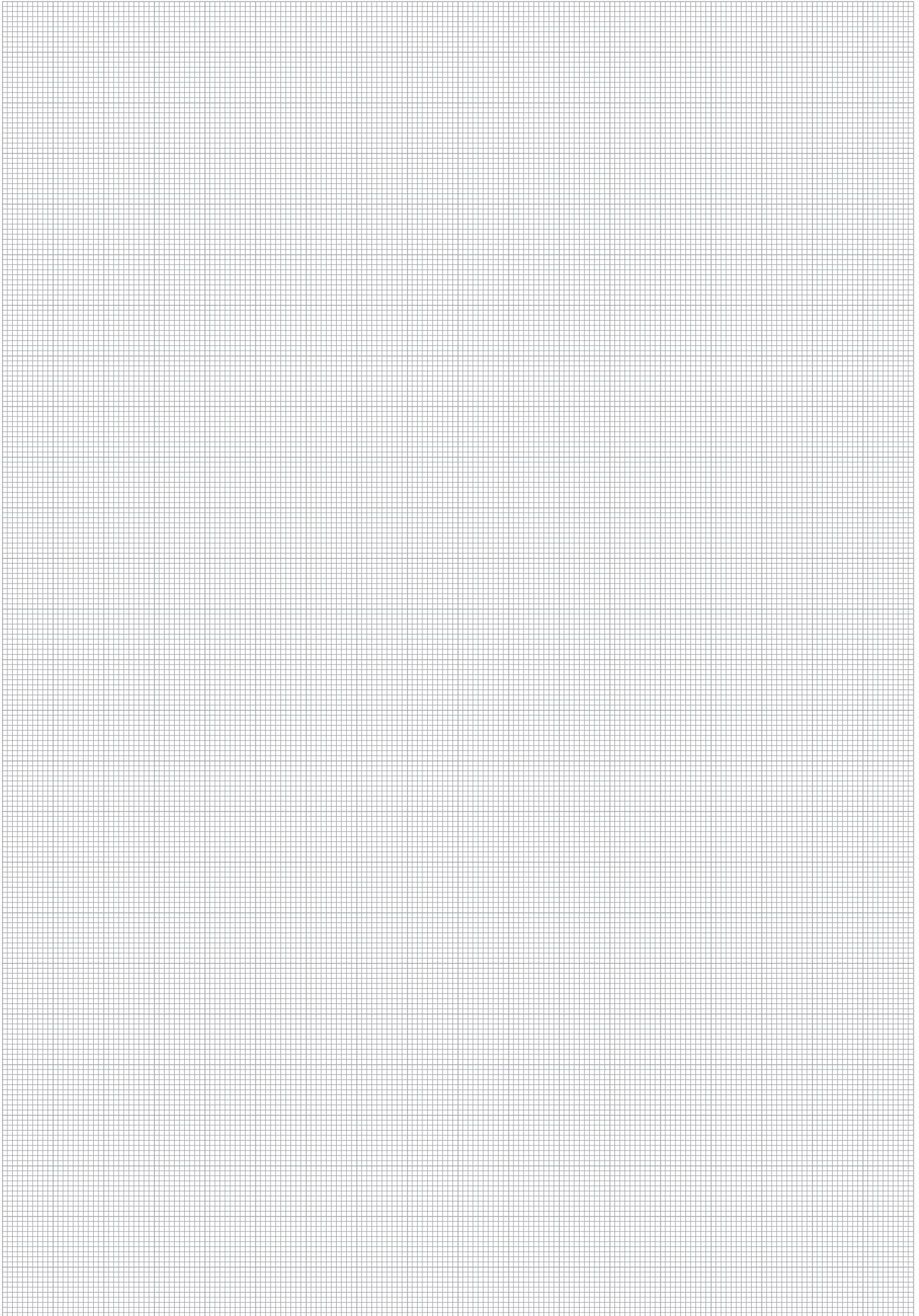

Series QRC-6D ▪ 6-Lines Multi Coupling

Material	Carbon Steel, Polyamide and Aluminum
Surface Finishing	Zinc-Nickel and Aluminum Components in Black Anodized
Standard Seal Material(s)	NBR (Buna-N®), Polyurethane, PTFE ²
Working Temperature	-25° C ... +100° C / -13° F ... +212° F
Connection	pressing the red button to allow the movement of the handle, followed by the alignment of the guide pins of the mobile half in the guide holes of the fixed manifold, allowing the joining of both parts
Disconnection	press the red button to allow the handler retraction
Connect Under Pressure	allowed
Application	Agricultural and Forestry Machinery, Construction Machinery

² Alternative seal materials are available on request.

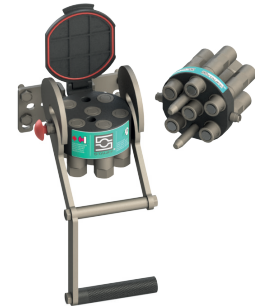

6D

Technical Data

Series	Lines	DN Zoll Inch	DN metric ISO 4397	Q _{max}		Working Pressure Connected		Spillage	
				l/min	US GPM	bar	PSI	ml	fl oz
QRC-6D1	6	1/4"	6,3	24	6.34	300	4351	0,042	.0014
QRC-6D2	6	3/8"	10	50	13.21	250	3626	0,048	.0016
QRC-6D3	6	1/2"	12,5	90	20.87	250	3626	0,060	.0020
QRC-6D35	2/4	1/2" / 3/4"	12,5 / 19	90 / 200	20.87 / 33.02	250	3626	0,090	.0030

Flow Characteristics

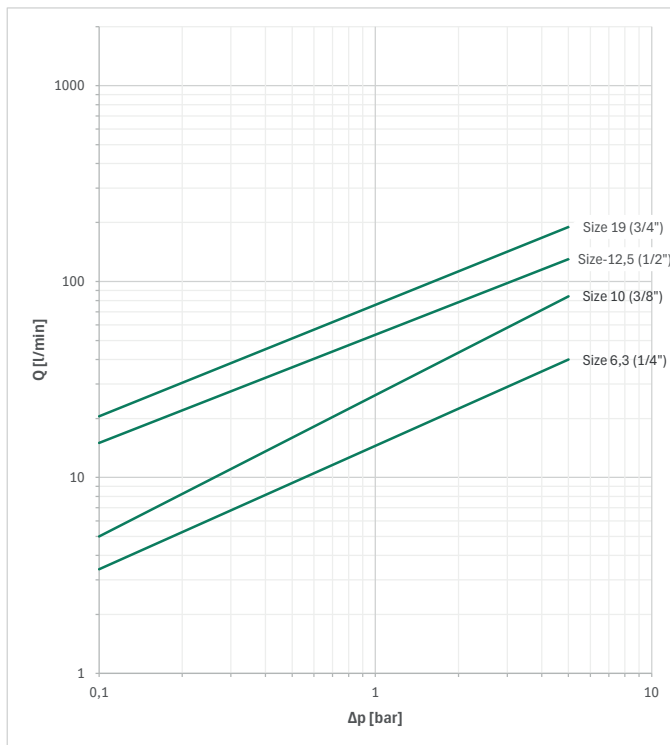

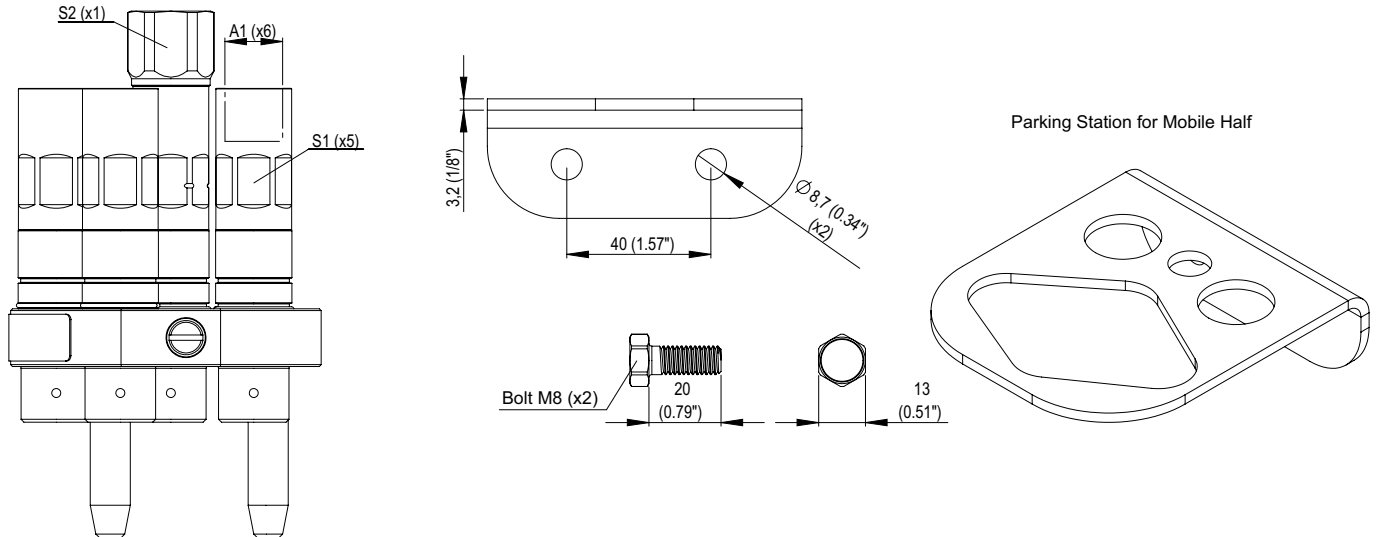
Series QRC-6D • 6-Lines Multi Coupling • Mobile Half

6D

Size mm (in)	Number of Couplers	A1 Thread	Standard Thread	Torque Nm	S1 mm (in)	S2 mm (in)	Mobile Half	Weight (lb)
							Ordering Codes	
6L: 6,3 (1/4")	6/6	11/16" UN ORFS (ext.) 6x	SAE J1453	32 - 38	15,9 (5/8")	17,5 (11/16")	QRC-6D1-M-02-S1-W264AU-ST	967 (2.13)
	6/6	9/16" UNF ORB (int.) 6x	SAE J1926	26 - 34	15,9 (5/8")	19,1 (3/4")	QRC-6D1-M-01-S1-W264AU-ST	807 (1.78)
6L: 10 (3/8")	4/6	3/8" BSP (int.) 4x	DIN 3852-2	40 - 56	19,1 (3/4")	-	QRC-6D2-M-G2-S1-W264AU-ST000AK	1.118 (2.46)
	6/6	M22x1,50 L15 (ext.) 6x	ISO 8434-1-L	74 - 96	19,1 (3/4")	22,2 (7/8")	QRC-6D2-M-L3-S1-W264AU-ST	1.669 (3.68)
	6/6	3/8" BSP (int.) 6x	DIN 3852-2	40 - 56	19,1 (3/4")	22,2 (7/8")	QRC-6D2-M-G2-S1-W264AU-ST	1.395 (3.08)
	6/6	1/2" BSP (int.) 6x	DIN 3852-2	72 - 88	25,4 (1")	25,4 (1")	QRC-6D2-M-G3-S1-W264AU-ST	1.795 (3.96)
	6/6	3/4" UNF ORB (int.) 6x	SAE J1926	48 - 62	23,8 (13/16")	23,8 (13/16")	QRC-6D2-M-U3-S1-W264AU-ST	1.599 (3.53)
6L: 12,5 (1/2")	5/6	1/2" BSP (int.) 5x	DIN 3852-2	72 - 88	22,2 (7/8")	-	QRC-6D3-M-G3-S1-W264AU-ST000AL	2.292 (5.05)
	4/6	1/2" BSP (int.) 4x	DIN 3852-2	72 - 88	22,2 (7/8")	-	QRC-6D3-M-G3-S1-W264AU-ST000AM	2.092 (4.61)
	4/6	13/16" UN ORFS (ext.) 4x	SAE J1453	42 - 52	22,2 (7/8")	-	QRC-6D3-M-03-S1-W264AU-ST000AM	2.348 (5.18)
	4/6	1" UNS ORFS (ext.) 4x	SAE J1453	58 - 70	22,2 (7/8")	-	QRC-6D3-M-04-S1-W264AU-ST000AM	2.453 (5.41)
	4/6	3/4" UNF ORB (int.) 4x	SAE J1926	48 - 62	22,2 (7/8")	-	QRC-6D3-M-U3-S1-W264AU-ST000AM	2.143 (4.72)
	6/6	3/4" UNF JIC (ext.) 6x	SAE J514	49 - 53	22,2 (7/8")	22,2 (7/8")	QRC-6D3-M-J3-S1-W264AU-ST	2.855 (6.30)
	6/6	13/16" UN ORFS (ext.) 6x	SAE J1453	42 - 52	22,2 (7/8")	22,2 (7/8")	QRC-6D3-M-03-S1-W264AU-ST	2.868 (6.32)
	6/6	M22x1,50 L15 (ext.) 6x	ISO 8434-1-L	74 - 96	22,2 (7/8")	22,2 (7/8")	QRC-6D3-M-L3-S1-W264AU-ST	2.876 (6.34)
	6/6	M24x1,50 S16 (ext.) 6x	ISO 8434-1-S	82 - 108	22,2 (7/8")	25,4 (1")	QRC-6D3-M-S3-S1-W264AU-ST	2.882 (6.35)
	6/6	1/2" BSP (int.) 6x	DIN 3852-2	72 - 88	22,2 (7/8")	25,4 (1")	QRC-6D3-M-G3-S1-W264AU-ST	2.534 (5.58)
	6/6	3/4" UNF ORB (int.) 6x	SAE J1926	48 - 62	22,2 (7/8")	25,4 (1")	QRC-6D3-M-U3-S1-W264AU-ST	2.541 (5.60)
6/6	1.1/16" UN ORB (int.) 6x	SAE J1926	90 - 116	30,0 (1.3/16")	33,4 (1.5/16")	QRC-6D3-M-U5-S1-W264AU-ST	3.045 (6.71)	
2L: 12,5 (1/2")	6/6	1/2" BSP (int.) 2x & 3/4" BSP (int.) 4x	DIN 3852-2	-	22,2 (7/8")	28,6 (1.1/8")	QRC-6D35-M-G3G5-S1-W264AU-ST	3712 (8.18)
4L: 19 (3/4")	6/6	3/4" UNF ORB (int.) 2x & 1.1/16" UN ORB (int.) 4x	SAE J1926	-	22,2 (7/8")	28,6 (1.1/8")	QRC-6D35-M-U3U5-S1-W264AU-ST	3598 (7.93)

To order a product with Parking Station, you should replace the „M“ behind the second hyphen with „MH“. Ex.: QRC-6D1-MH-02-S1-W264AU-ST

Series QRC-6D • 6-Lines Multi Coupling • Parking Station for Mobile Half

Size mm (in)	Ordering Codes
6L: 6,3 (1/4")	QRC-6D1-HM-W3AU-ST
6L: 10 (3/8")	QRC-6D2-HM-W3AU-ST
6L: 12,5 (1/2")	QRC-6D3-HM-W3AU-ST
2L: 12,5 (1/2") & 4L: 19 (3/4")	QRC-6D3D5-HM-W3AU-ST



Series QRC-6D • 6-Lines Multi Coupling • Fixed Half

6D

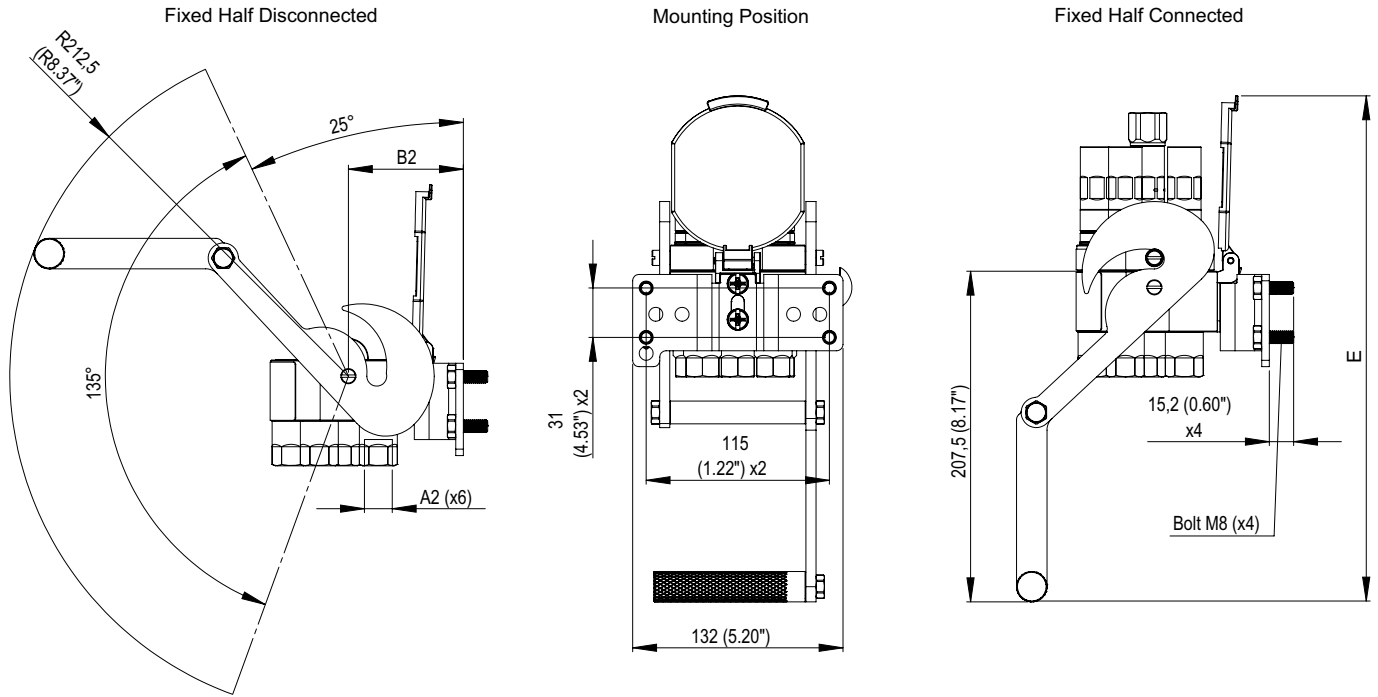

Size mm (in)	Number of Couplers	A2 Thread	Standard Thread	Torque Nm	B2 mm (in)	E mm (in)	Fixed Half	Weight (⁹ /lbs)
							Ordering Codes	
6L: 6,3 (1/4")	6/6	11/16"UN ORFS (ext.) 6x	SAE J1453	32 - 38	62,1 (2.34")	298,8 (11.76")	QRC-6D1-F-02-S1-W264AU-ST	2.024 (4.46)
	6/6	1/4" BSP (int.) 6x	DIN 3852-2	24 - 32	62,1 (2.34")	298,8 (11.76")	QRC-6D1-F-G1-S1-W264AU-ST	1.880 (4.14)
	6/6	9/16" UNF ORB (int.) 6x	SAE J1926	26 - 34	62,1 (2.34")	298,8 (11.76")	QRC-6D1-F-01-S1-W264AU-ST	1.823 (4.02)
6L: 10 (3/8")	6/6	M22x1,50 L15 (ext.) 6x	ISO 8434-1-L	74 - 96	71,7 (2.82")	316,6 (12.46")	QRC-6D2-F-L3-S1-W264AU-ST	2.769 (6.10)
	6/6	3/8" BSP (int.) 6x	DIN 3852-2	40 - 56	71,7 (2.82")	316,6 (12.46")	QRC-6D2-F-G2-S1-W264AU-ST	2.430 (5.36)
	6/6	1/2" BSP (int.) 6x	DIN 3852-2	72 - 88	71,7 (2.82")	316,6 (12.46")	QRC-6D2-F-G3-S1-W264AU-ST	2.494 (5.50)
	6/6	3/4" UNF ORB (int.) 6x	SAE J1926	48 - 62	71,7 (2.82")	316,6 (12.46")	QRC-6D2-F-U3-S1-W264AU-ST	2.458 (5.42)
6L: 12,5 (1/2")	4/6	M24x1,50 S16 (ext.) 4x	ISO 8434-1-S	82 - 108	77,9 (3.07")	329,6 (12.98")	QRC-6D3-F-S3-S1-W264AU-ST000AM	3.860 (8.51)
	4/6	3/4" UNF ORB (int.) 4x	SAE J1926	48 - 62	77,9 (3.07")	329,6 (12.98")	QRC-6D3-F-U3-S1-W264AU-ST000AM	3.492 (7.70)
	6/6	13/16"UN ORFS (ext.) 6x	SAE J1453	42 - 52	77,9 (3.07")	329,6 (12.98")	QRC-6D3-F-03-S1-W264AU-ST	4.128 (9.10)
	6/6	M22x1,50 L15 (ext.) 6x	ISO 8434-1-L	74 - 96	77,9 (3.07")	329,6 (12.98")	QRC-6D3-F-L3-S1-W264AU-ST	4.099 (9.04)
	6/6	1/2" BSP (int.) 6x	DIN 3852-2	72 - 88	77,9 (3.07")	329,6 (12.98")	QRC-6D3-F-G3-S1-W264AU-ST	3.699 (8.15)
	6/6	3/4" UNF ORB (int.) 6x	SAE J1926	48 - 62	77,9 (3.07")	329,6 (12.98")	QRC-6D3-F-U3-S1-W264AU-ST	3.721 (8.20)
	6/6	1.1/16" UN ORB (int.) 6x	SAE J1926	90 - 116	77,9 (3.07")	329,6 (12.98")	QRC-6D3-F-U5-S1-W264AU-ST	3.896 (8.59)
	6/6	1/2" BSP (int.) 2x & 3/4" BSP (int.) (int.) 4x	DIN 3852-2	-	99,3 (3.91")	329,9 (12.99")	QRC-6D35-F-G3G5-S1-W264AU-ST	4.874 (10.75)
4L: 19 (3/4")	6/6	3/4" UNF ORB (int.) 2x & 1.1/16" UN ORB (int.) 4x	SAE J1926	-	99,3 (3.91")	329,9 (12.99")	QRC-6D35-F-U3U5-S1-W264AU-ST	4.829 (10.65)



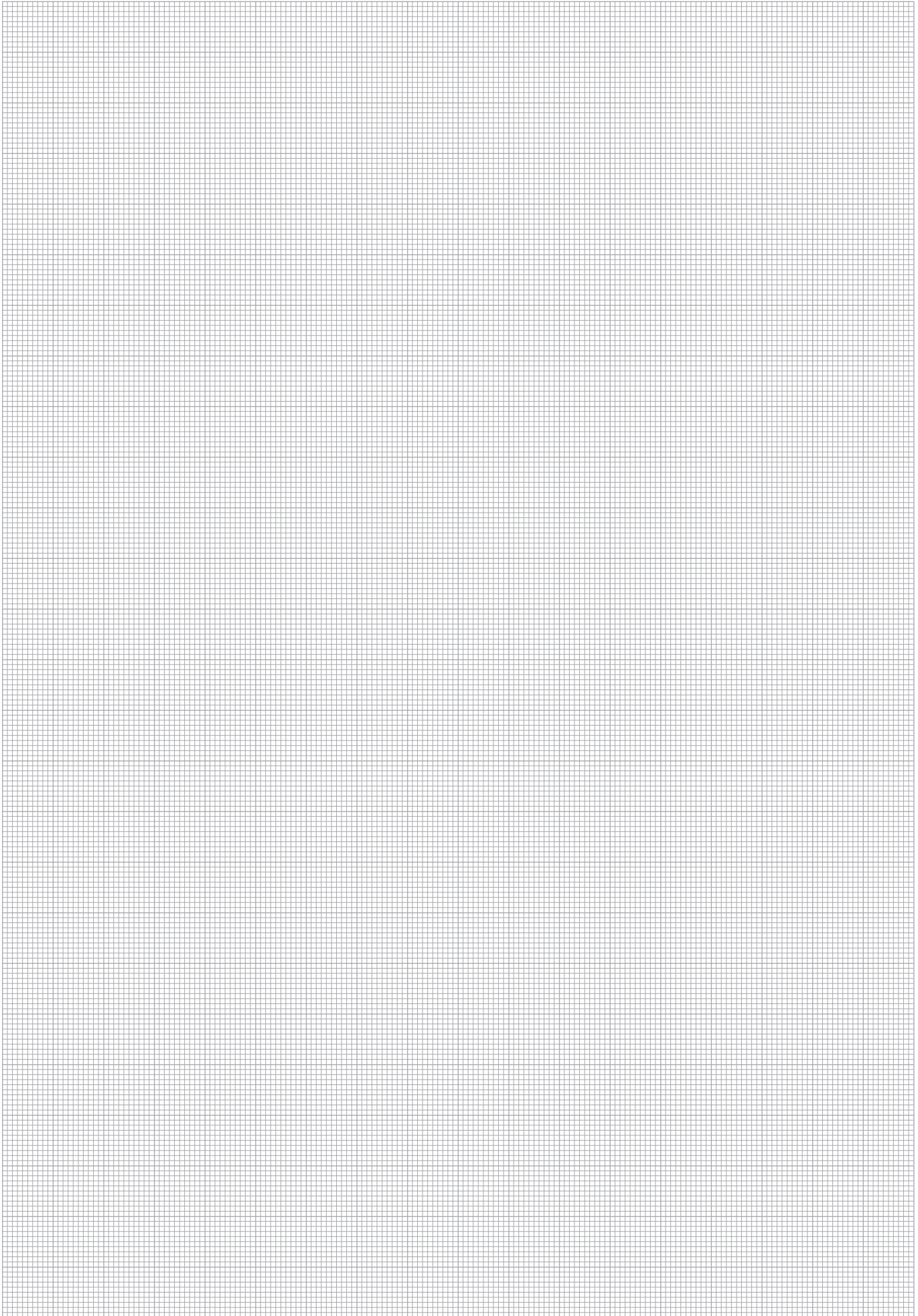

Series QRC-4DV • 4-Lines Multi Coupling Mounted on Front Loader Hydraulic Valves

Material	Carbon Steel, Polyamide and Aluminum
Surface Finishing	Zinc-Nickel and Aluminum Components in Black Anodized
Standard Seal Material(s)	NBR (Buna-N®), Polyurethane, PTFE ²
Working Temperature	-25° C ... +100° C / -13° F ... +212° F
Connection	pressing the red button to allow the movement of the handle, followed by the alignment of the guide pins of the mobile half in the guide holes of the fixed manifold, allowing the joining of both parts
Disconnection	press the red button to allow the handler retraction
Connect Under Pressure	allowed
Application	Agricultural and Forestry Machinery

² Alternative seal materials are available on request.



4DV

Technical Data

Series	Lines	DN Zoll Inch	DN metric ISO 4397	Q _{max}		Working Pressure Connected		Spillage	
				l/min	US GPM	bar	PSI	ml	fl oz
QRC-4DV2	4	3/8"	10	50	13.21	270	3916	0,032	.0010

Flow Characteristics

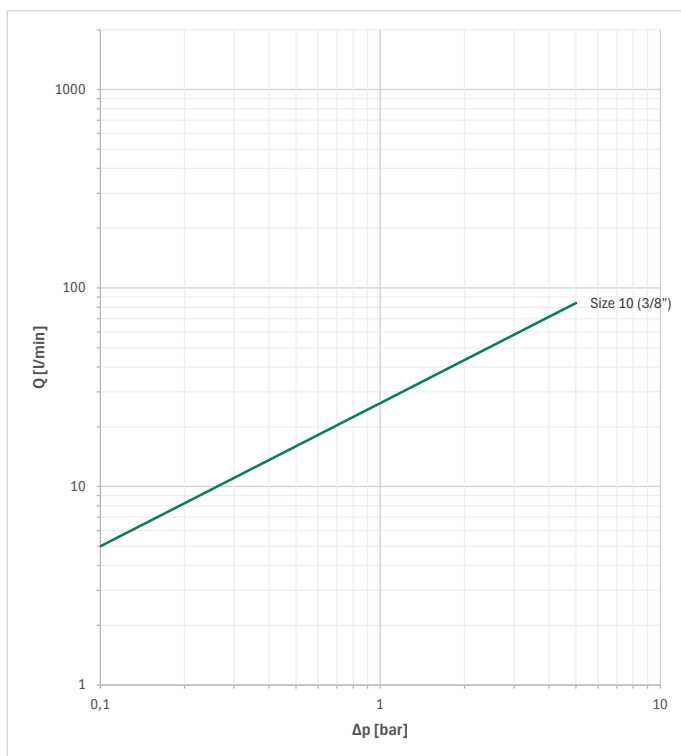

Series QRC-4DV • 4-Lines Multi Coupling Mounted on Front Loader Hydraulic Valves • Mobile Half

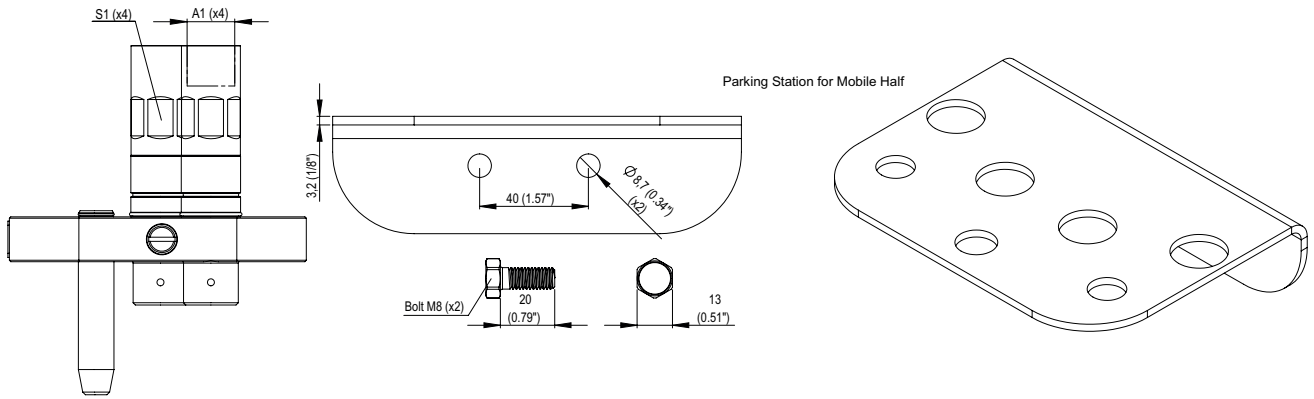
4DV

Size mm (in)	Number of Couplers	A1 Thread	Standard Thread	Torque Nm	S1 mm (in)	Mobile Half	Weight (9/lbs)
4L: 10 (3/8")	4/4	13/16"UN ORFS (ext.) 4x	SAE J1453	42 - 52	19,1 (3/4")	Ordering Codes QRC-4DV2-M-03-S1-W264AU-ST	2.430 (5.36)
	4/4	M22x1,50 L15 (ext.) 4x	ISO 8434-1-L	74 - 96	19,1 (3/4")	QRC-4DV2-M-L3-S1-W264AU-ST	2.460 (5.42)
	4/4	3/8" BSP (int.) 4x	DIN 3852-2	40 - 56	19,1 (3/4")	QRC-4DV2-M-G2-S1-W264AU-ST	1.991 (4.39)
	4/4	1/2" BSP (int.) 4x	DIN 3852-2	72 - 88	25,4 (1")	QRC-4DV2-M-G3-S1-W264AU-ST	2.231 (4.92)
	4/4	1/2" NPTF (int.) 4x	ANSI B1.20.3	52 - 66	25,4 (1")	QRC-4DV2-M-NF3-S1-W264AU-ST	2.245 (4.95)

To order a product with Parking Station, you should replace the „M“ behind the second hyphen with „MH“.
Ex.: QRC-4DV2-MH-03-S1-W264AU-ST

Series QRC-4DV • 4-Lines Multi Coupling Mounted on Front Loader Hydraulic Valves • Parking Station for Mobile Half

Size mm (in)	Ordering Codes
4L: 10 (3/8")	QRC-4DV2-HM-W3AU-ST



**Series QRC-4DV ▪ 4-Lines Multi Coupling
Mounted on Front Loader Hydraulic Valves ▪ Fixed Half**

4DV

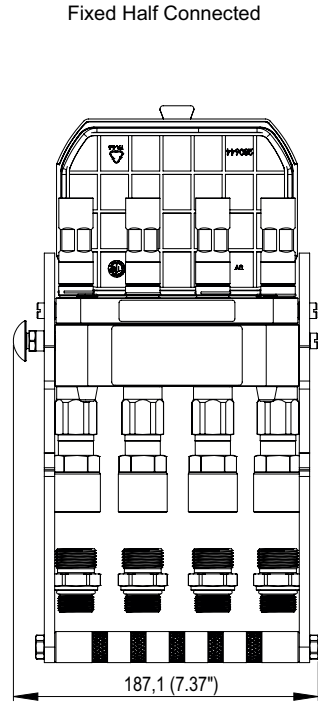
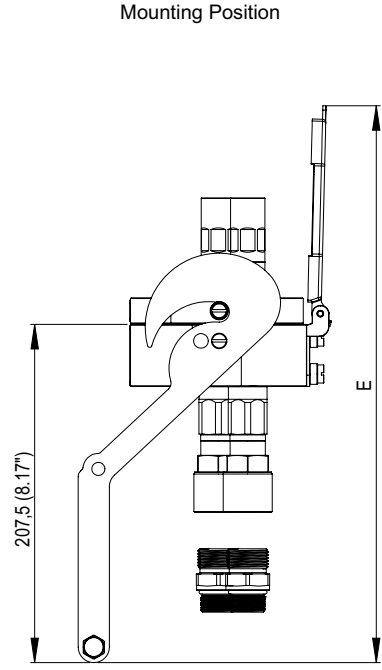
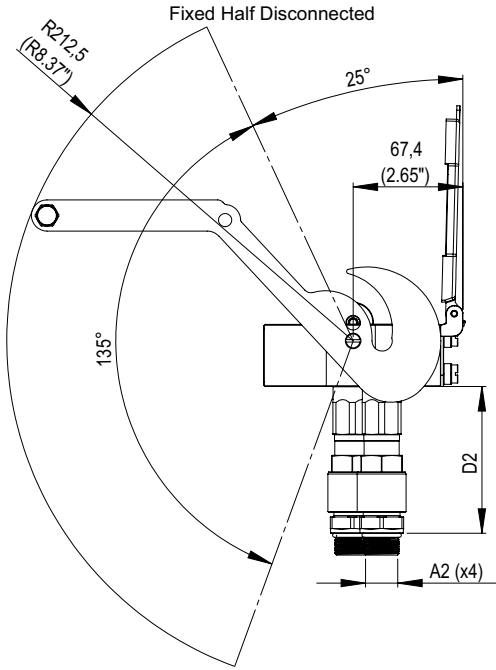

Size mm (in)	Number of Couplers	A2 Thread	Standard Thread	Torque Nm	D2 mm (in)	E mm (in)	Fixed Half	Weight (⁹ /lbs)
							Ordering Codes	
4L: 10 (3/8")	4/4	7/8"UNF ORB (ext.) 4x	SAE J1926	58 - 74	88,5 (3.48")	340,7 (13.42")	QRC-4DV2-F-G3-S1-W264AU-ST*	4.083 (9.00)
	4/4	1/2" BSP (ext.) 4x	DIN 3852-2	72 - 88	88,5 (3.48")	340,7 (13.42")	QRC-4DV2-F-G3-S1-W264AU-ST*	4.099 (9.04)
	4/4	M22x1,50 ORB (ext.) 4x	ISO 6149	74 - 96	88,5 (3.48")	340,7 (13.42")	QRC-4DV2-F-M3S-S1-W264AU-ST*	4.089 (9.01)
	4/4	7/8"UNF ORB (ext.) 4x	SAE J1926	58 - 74	88,5 (3.48")	340,7 (13.42")	QRC-4DV2-F-U4M-S1-W264AU-ST000BB**	4.083 (9.00)

* To be used with control valve SDM122 / RMC202

** To be used with control valve DN90FC



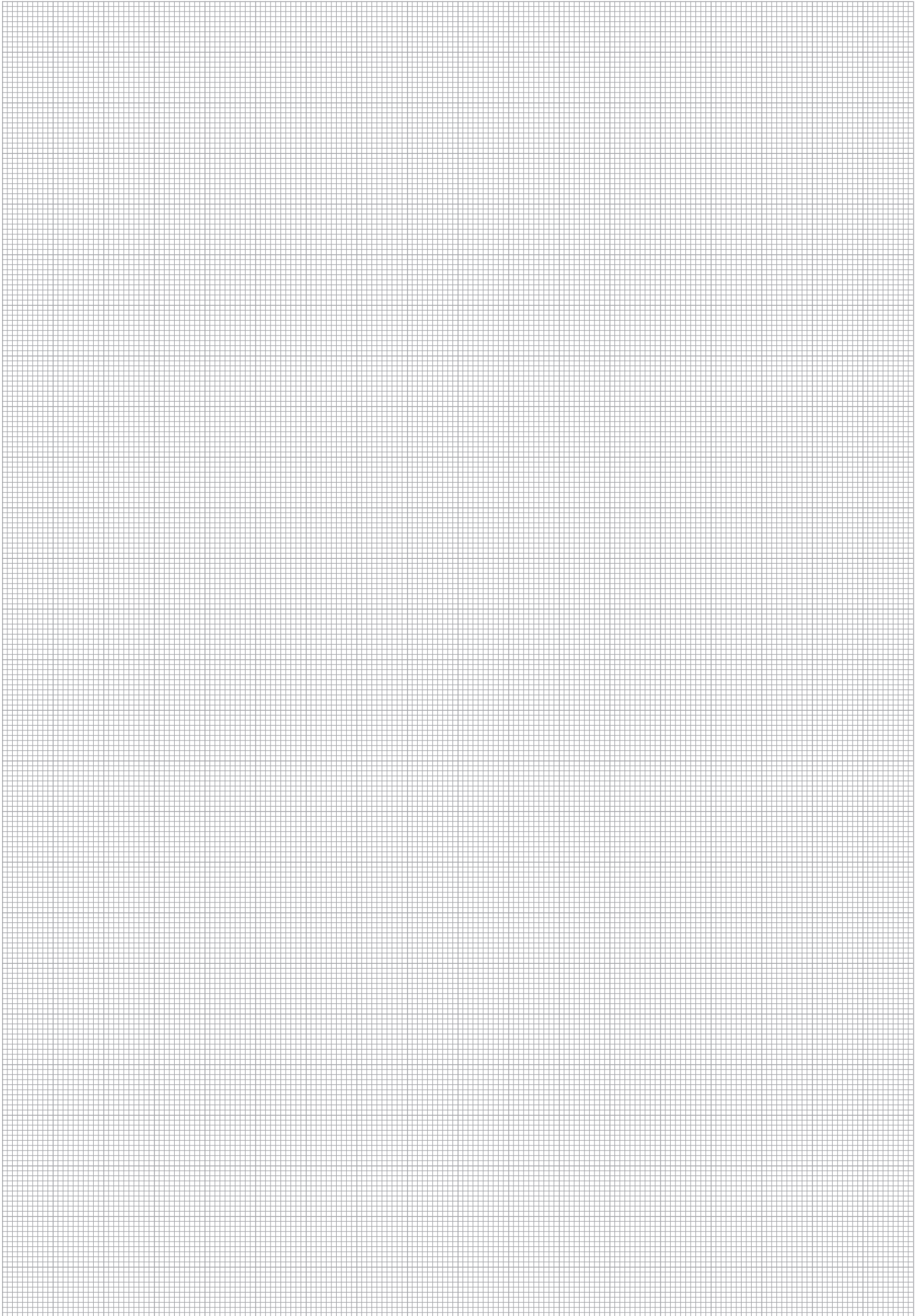

Series QRC-6DE ▪ 5-Lines Multi Coupling with a Port for an Electric Socket

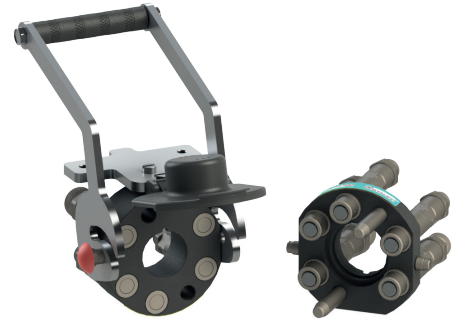

Material	Carbon Steel, Polyamide and Aluminum
Surface Finishing	Zinc-Nickel and Aluminum Components in Black Anodized
Standard Seal Material(s)	NBR (Buna-N®), Polyurethane, PTFE ²
Working Temperature	-25° C ... +100° C / -13° F ... +212° F
Connection	pressing the red button to allow the movement of the handle, followed by the alignment of the guide pins of the mobile half in the guide holes of the fixed manifold, allowing the joining of both parts
Disconnection	press the red button to allow the handler retraction
Connect Under Pressure	allowed
Application	Agricultural and Forestry Machinery

² Alternative seal materials are available on request.

6DE

Technical Data

Series	Lines	DN Zoll Inch	DN metric ISO 4397	Q _{max}		Working Pressure Connected		Spillage	
				l/min	US GPM	bar	PSI	ml	fl oz
QRC-6DE2	5	3/8"	10	50	13.21	250	3626	0,040	.0010

Flow Characteristics

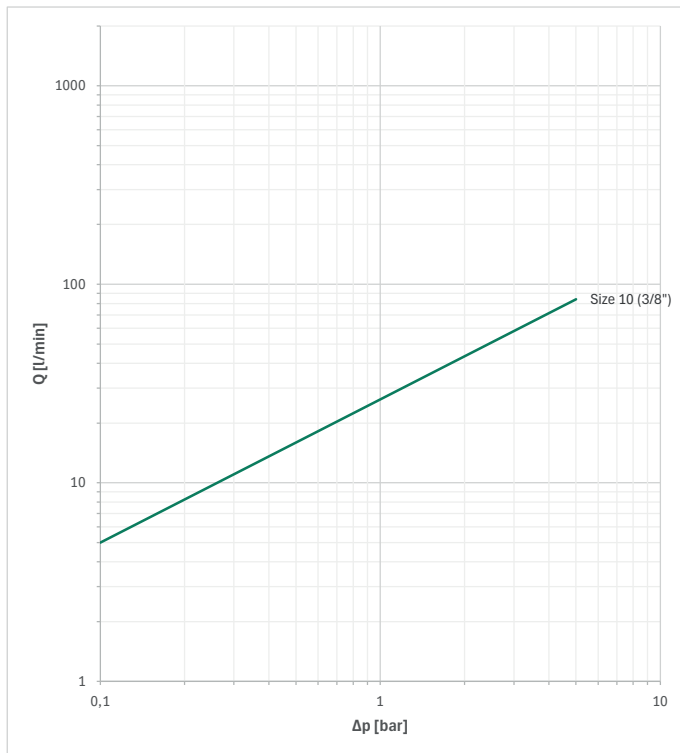

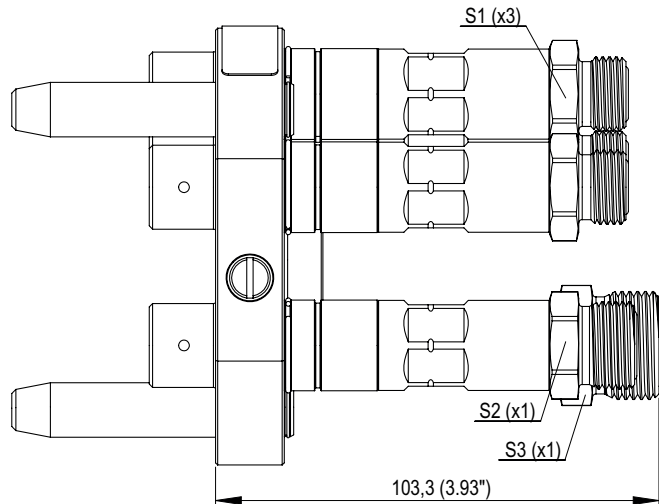
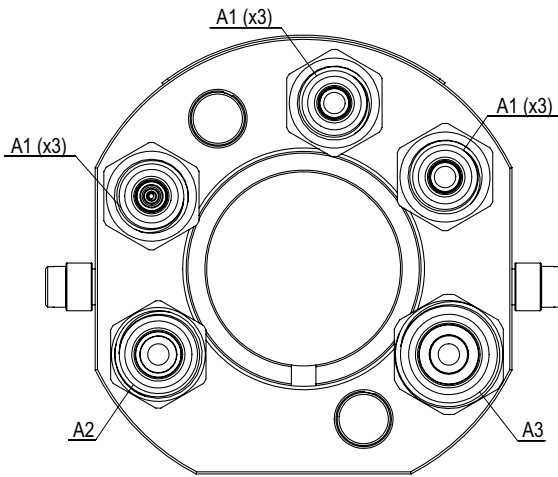
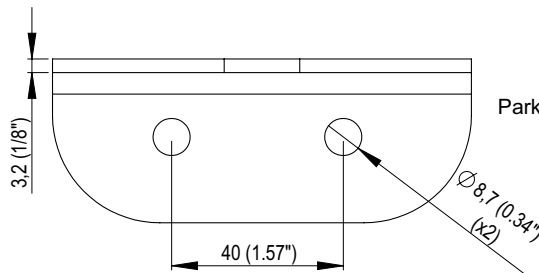
**Series QRC-6DE • 5-Lines Multi Coupling
with a Port for an Electric Socket • Mobile Half**

6DE

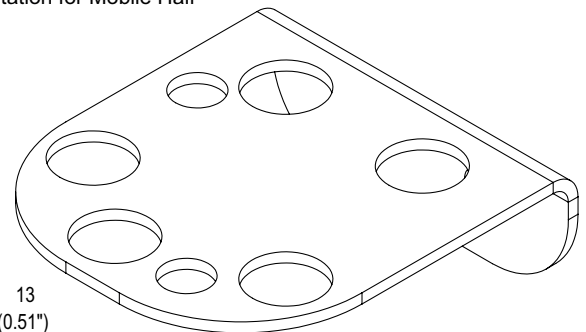
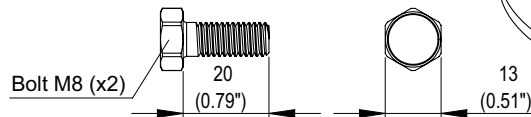
Parking Station for Mobile Half



Size mm (in)	Number of Couplers	A1 Thread	A2 Thread	A3 Thread	Standard Thread	S1 mm (in)	S2 mm (in)	S3 mm (in)	Mobile Half Ordering Codes	Weight (^g /lbs)
5L: 10 (3/8")	2/5	11/16"UN ORFS (ext.) 2x	-	-	SAE J1453	22,2 (7/8")	-	-	QRC-6DE2-M-02-S1-W264AU-STC00AN	1.144 (2.52)
	3/5	11/16"UN ORFS (ext.) 1x	13/16"UN ORFS (ext.) 1x	1"UNS ORFS (ext.) 1x	SAE J1453	22,2 (7/8")	22,2 (7/8")	25,4 (1")	QRC-6DE2-M-020304-S1-W264AU-STC00AL	1.362 (3.00)
	5/5	11/16"UN ORFS (ext.) 3x	13/16"UN ORFS (ext.) 1x	1"UNS ORFS (ext.) 1x	SAE J1453	22,2 (7/8")	22,2 (7/8")	25,4 (1")	QRC-6DE2-M-020304-S1-W264AU-STC	1.690 (3.73)
	5/5	11/16"UN ORFS (ext.) 3x	13/16"UN ORFS (ext.) 1x	13/16"UN ORFS (ext.) 1x	SAE J1453	22,2 (7/8")	22,2 (7/8")	25,4 (1")	QRC-6DE2-M-0203-S1-W264AU-STC	1.650 (3.64)
	5/5	13/16"UN ORFS (ext.) 3x	13/16"UN ORFS (ext.) 1x	13/16"UN ORFS (ext.) 1x	SAE J1453	22,2 (7/8")	22,2 (7/8")	25,4 (1")	QRC-6DE2-M-03-S1-W264AU-STC	1.671 (3.68)

To order a product with Parking Station, you should replace the „M“ behind the second hyphen with „MH“.
Ex.: QRC-6DE1A2-MH-020304-S1-W264AU-STC

**Series QRC-6DE • 5-Lines Multi Coupling
with a Port for an Electric Socket • Parking Station for Mobile Half**

Size mm (in)	Ordering Codes
5L: 10 (3/8")	QRC-6DE1A2-HM-W3AU-ST



**Series QRC-6DE ▪ 5-Lines Multi Coupling
with a Port for an Electric Socket ▪ Fixed Half**

6DE

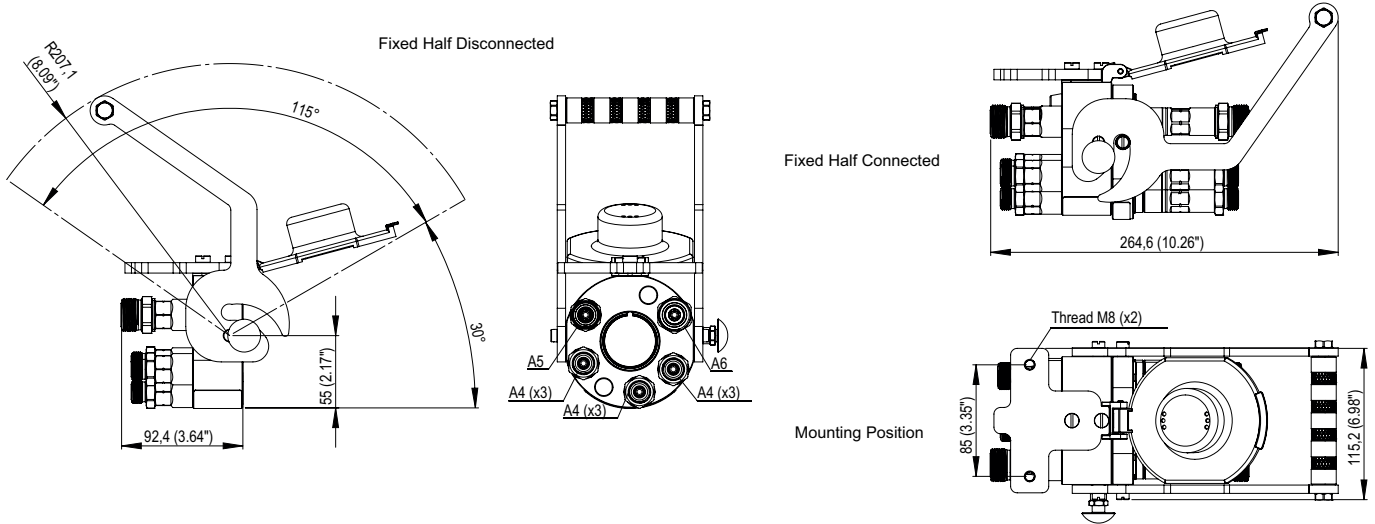

Size mm (in)	Number of Couplers	A4 Thread	A5 Thread	A6 Thread	Standard Thread	Fixed Half	Weight (⁹ /lbs)
						Ordering Codes	
5L: 10 (3/8")	5/5	11/16"UN ORFS (ext.) 3x	13/16"UN ORFS (ext.) 1x	1"UNS ORFS (ext.) 1x	SAE J1453	QRC-6DE2-F-020304-S1-W264AU-STC	2.675 (5.90)
	5/5	11/16"UN ORFS (ext.) 3x	13/16"UN ORFS (ext.) 1x	13/16"UN ORFS (ext.) 1x	SAE J1453	QRC-6DE2-F-0203-S1-W264AU-STC	2.635 (5.81)
	5/5	13/16"UN ORFS (ext.) 3x	13/16"UN ORFS (ext.) 1x	13/16"UN ORFS (ext.) 1x	SAE J1453	QRC-6DE2-F-03-S1-W264AU-STC	2.656 (5.86)



